

- 1) USB Differential Pairs - 90 Ohm
 (A)USB_N and USB_P
 (B)MCU_GPIO42 and MCU_GPIO43

- 2)ADC Differential pair Impedance Matching
 (A)HSEC_ADC even pins should match with HSEC_ADC + 1 pin(ie HSEC_ADC-C2 should match with HSEC_ADC-C3)
 (B)MCU_ADC even pins should match with MCU_ADC + 1 pin(ie MCU_ADC-A0 should match with MCU_ADC-A1)

- 3)ETHERNET and ETHERCAT Differential pairs
 (A)TD_P and TD_N
 (B)RD_P and RD_N

Revision History				
Rev	ECN #	Approved Date	Approved by	Notes
E1	N/A	N/A	N/A	Initial
E2	N/A	N/A	N/A	Fixed Ethernet MDC Bug in PCB Replaced U20 with an inverting buffer
A	N/A	N/A	N/A	Public Release
B	N/A	N/A	N/A	Changed Default clock to 25MHz Added 1V2, 3V3, and ERRORSTS to HSEC connector Enhanced J2 to support 2 data lines

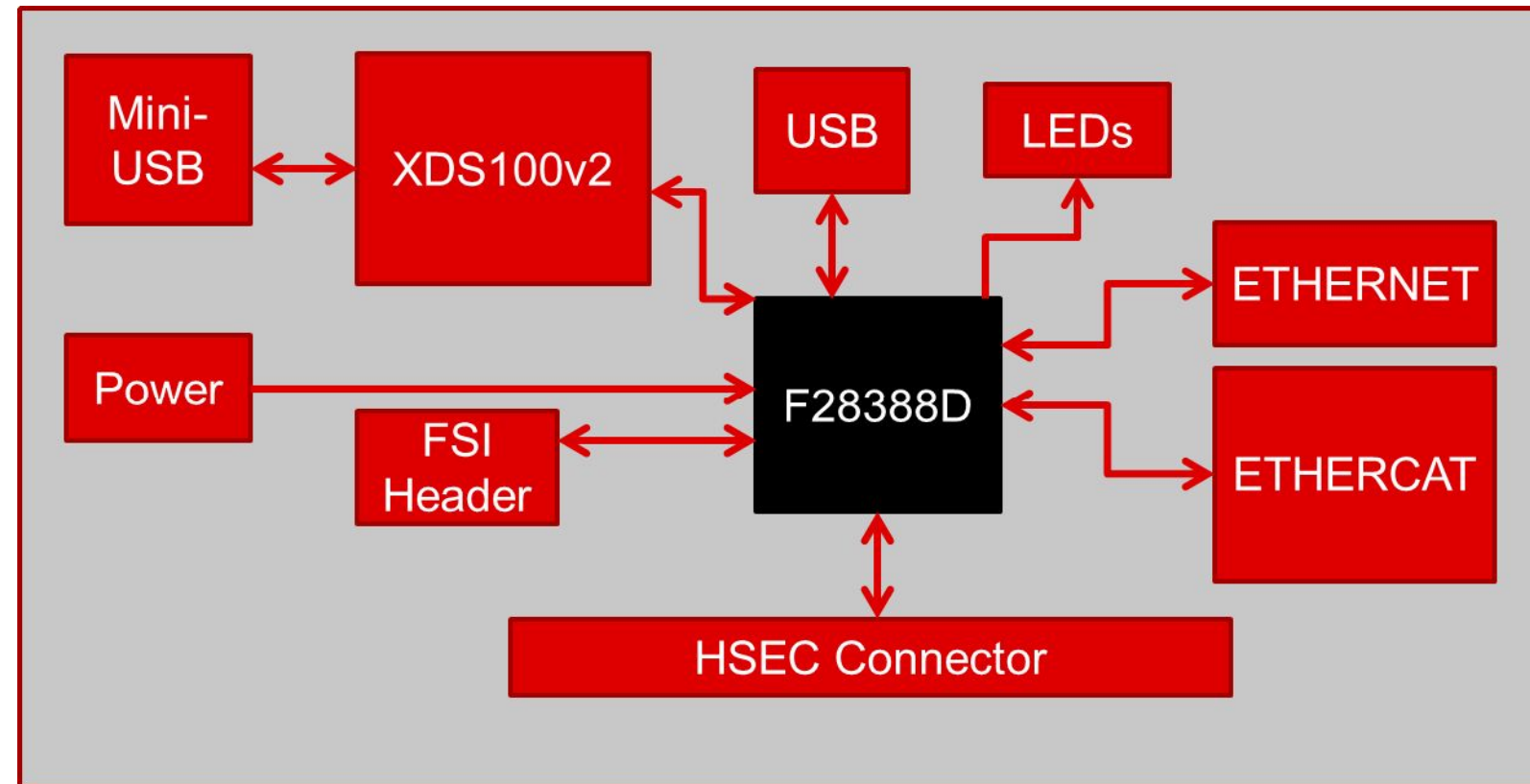

This controlCARD does not support the High Density(HD) connector, or EMIF, as previously supported by TMDSCNCF28379D.

Texas Instruments and/or its licensors do not warrant the accuracy or completeness of this specification or any information contained therein. Texas Instruments and/or its licensors do not warrant that this design will meet the specifications, will be suitable for your application or fit for any particular purpose, or will operate in an implementation. Texas Instruments and/or its licensors do not warrant that the design is production worthy. You should completely validate and test your design implementation to confirm the system functionality for your application.

Orderable: TMDSCNCD28388D	Designed for: Public Release	Mod. Date: 10/18/2022	 TEXAS INSTRUMENTS http://www.ti.com © Texas Instruments 2018
TID #: N/A	Project Title: TMS320F28388D controlCARD	Sheet: 1 of 11	
Number: MCU063	Rev: B	Assembly Variant: 003	Size: B
SVN Rev: Version control disabled	Drawn By: Cody Watkins	File: MCU063B_CoverSheet.SchDoc	Contact: http://www.ti.com/support
Engineer: Cody Watkins			

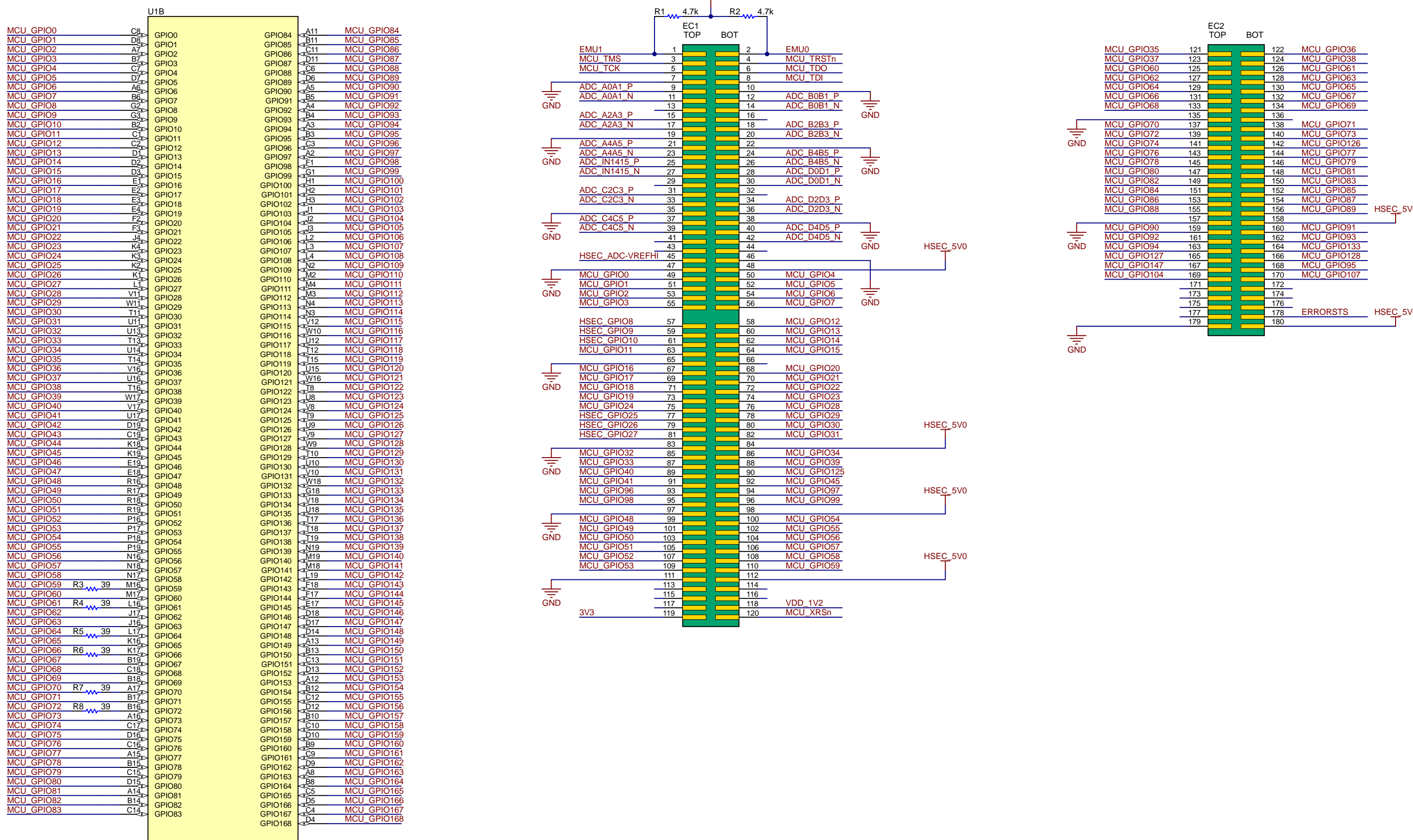

TMS320F28388DZWT5

Texas Instruments and/or its licensors do not warrant the accuracy or completeness of this specification or any information contained therein. Texas Instruments and/or its licensors do not warrant that this design will meet the specifications, will be suitable for your application or fit for any particular purpose, or will operate in an implementation. Texas Instruments and/or its licensors do not warrant that the design is production worthy. You should completely validate and test your design implementation to confirm the system functionality for your application.

Orderable: TMS320F28388D	Designed for: Public Release	Mod. Date: 10/18/2022
TID #: N/A	Project Title: TMS320F28388D controlCARD	
Number: MCU063	Rev: B	Sheet Title:
SVN Rev: Version control disabled	Assembly Variant: 003	Sheet: 2 of 11
Drawn By: Cody Watkins	File: MCU063B_GPIO.SchDoc	Size: B
Engineer: Cody Watkins	Contact: http://www.ti.com/support	



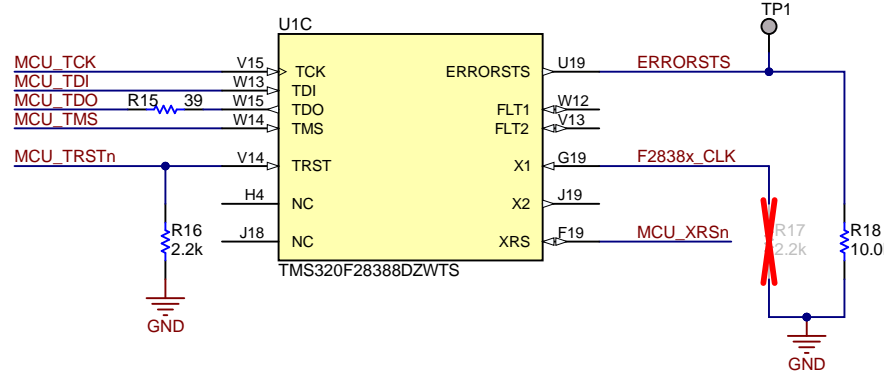

LEDs

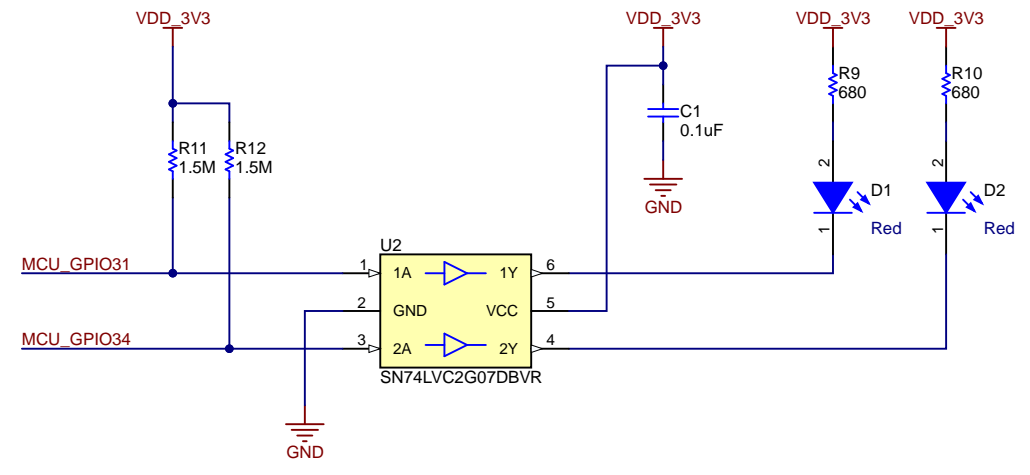

Micro-SD Card

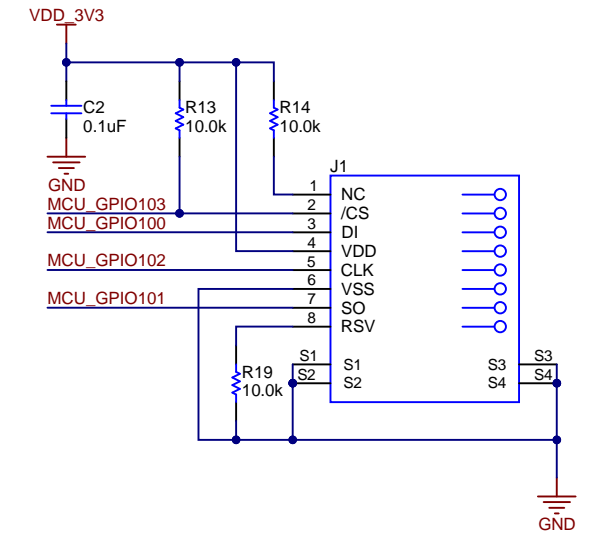

Reset & Voltage Monitoring

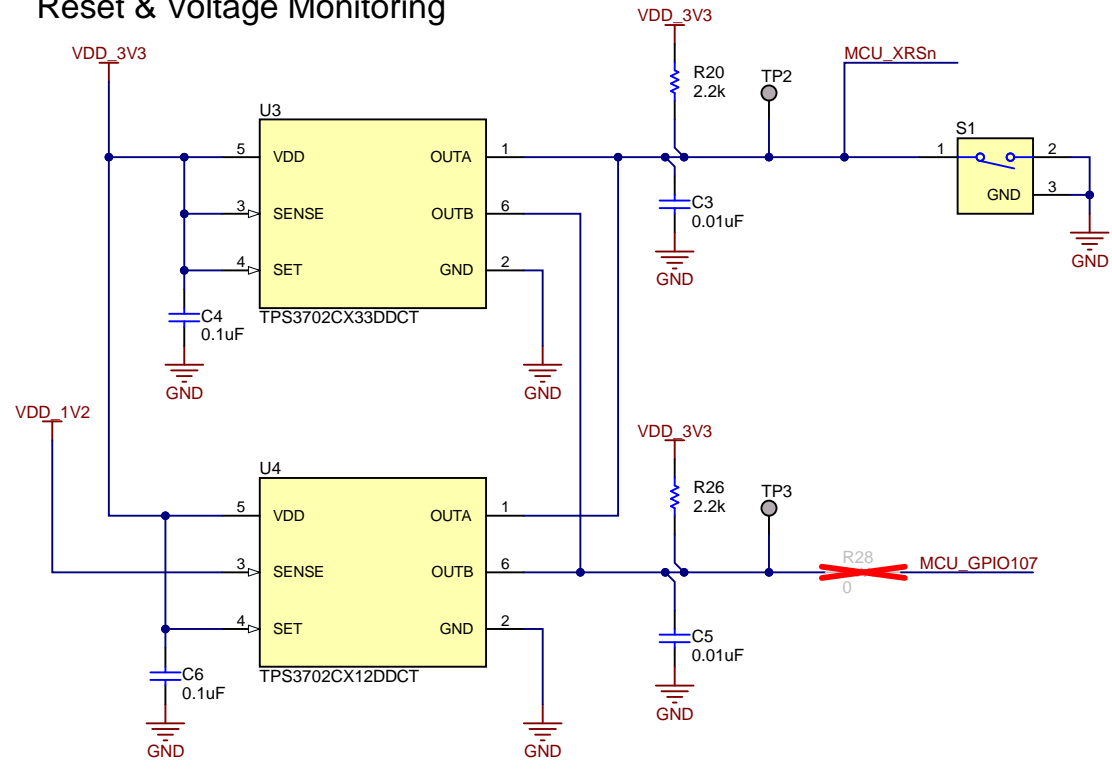

1	FSI-RX0	2	FSI-RX1/GND
3	FSI-RXCLK	4	GND
5	FSI-TX0	6	FSI-TX1/GND
7	FSI-TXCLK	8	GND
9	KEY	10	3V3

FSI Header

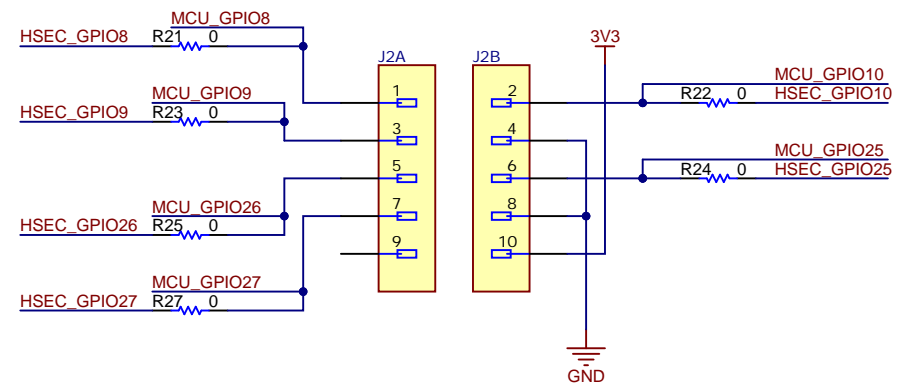

Clock Source Selection

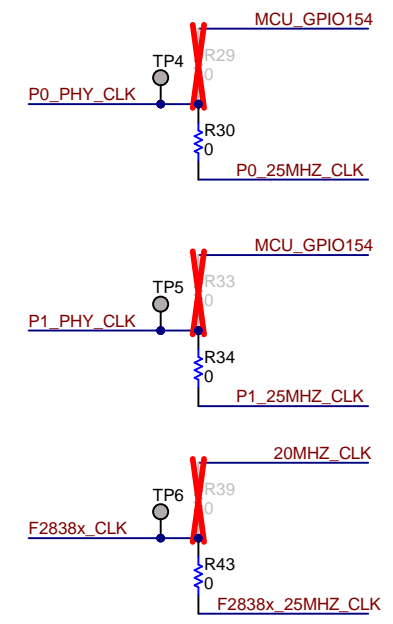

Boot Mode Selection Switch

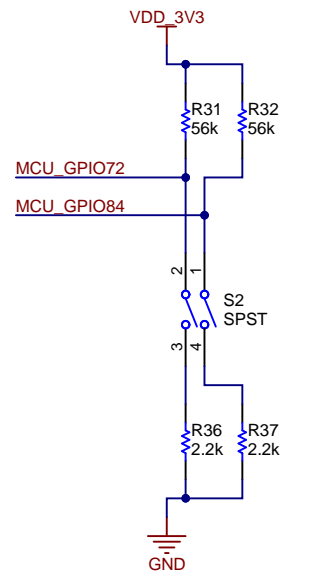

20MHz Clock

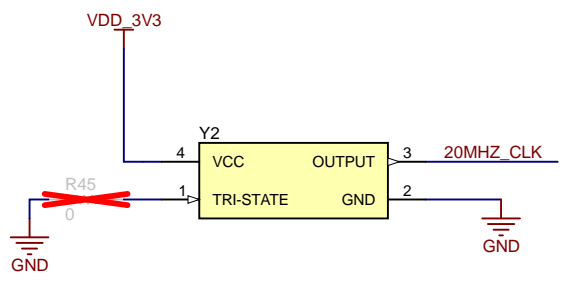

25MHz Clock

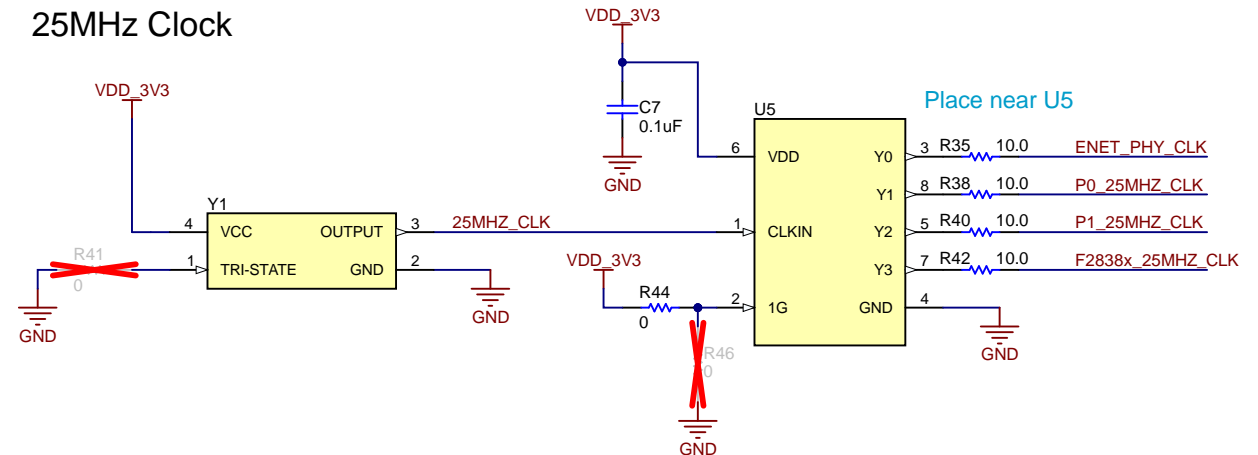

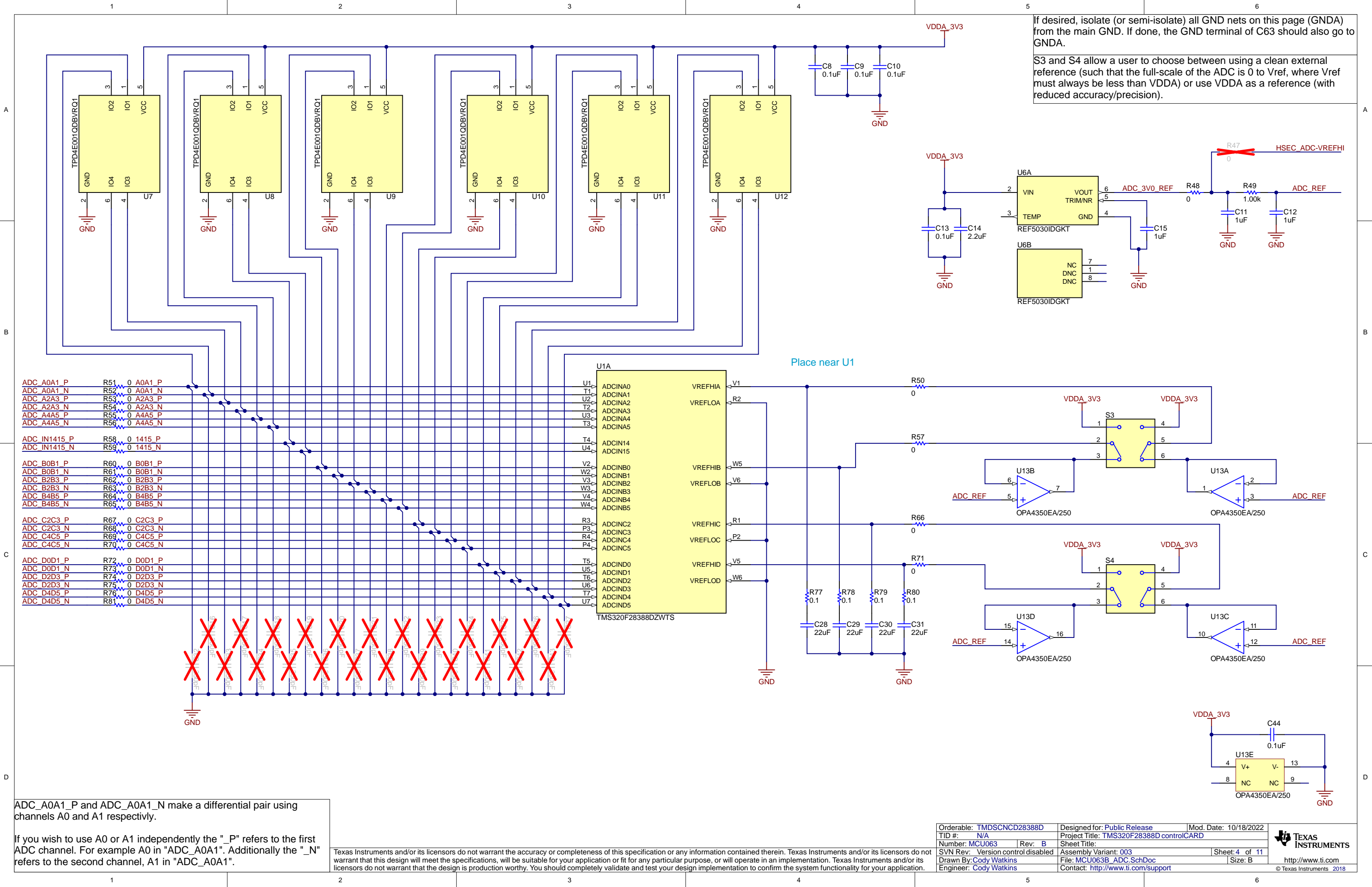

If desired, isolate (or semi-isolate) all GND nets on this page (GNDA) from the main GND. If done, the GND terminal of C63 should also go to GNDA.

S3 and S4 allow a user to choose between using a clean external reference (such that the full-scale of the ADC is 0 to Vref, where Vref must always be less than VDDA) or use VDDA as a reference (with reduced accuracy/precision).

ADC_A0A1_P	R51	0	A0A1_P
ADC_A0A1_N	R52	0	A0A1_N
ADC_A2A3_P	R53	0	A2A3_P
ADC_A2A3_N	R54	0	A2A3_N
ADC_A4A5_P	R55	0	A4A5_P
ADC_A4A5_N	R56	0	A4A5_N
ADC_IN1415_P	R58	0	1415_P
ADC_IN1415_N	R59	0	1415_N
ADC_B0B1_P	R60	0	B0B1_P
ADC_B0B1_N	R61	0	B0B1_N
ADC_B2B3_P	R62	0	B2B3_P
ADC_B2B3_N	R63	0	B2B3_N
ADC_B4B5_P	R64	0	B4B5_P
ADC_B4B5_N	R65	0	B4B5_N
ADC_C2C3_P	R67	0	C2C3_P
ADC_C2C3_N	R68	0	C2C3_N
ADC_C4C5_P	R69	0	C4C5_P
ADC_C4C5_N	R70	0	C4C5_N
ADC_D0D1_P	R72	0	D0D1_P
ADC_D0D1_N	R73	0	D0D1_N
ADC_D2D3_P	R74	0	D2D3_P
ADC_D2D3_N	R75	0	D2D3_N
ADC_D4D5_P	R76	0	D4D5_P
ADC_D4D5_N	R81	0	D4D5_N

ADC_A0A1_P and ADC_A0A1_N make a differential pair using channels A0 and A1 respectively.

If you wish to use A0 or A1 independently the "_P" refers to the first ADC channel. For example A0 in "ADC_A0A1". Additionally the "_N" refers to the second channel, A1 in "ADC_A0A1".

Texas Instruments and/or its licensors do not warrant the accuracy or completeness of this specification or any information contained therein. Texas Instruments and/or its licensors do not warrant that this design will meet the specifications, will be suitable for your application or fit for any particular purpose, or will operate in an implementation. Texas Instruments and/or its licensors do not warrant that the design is production worthy. You should completely validate and test your design implementation to confirm the system functionality for your application.

Orderable: TMS320F28388D	Designed for: Public Release	Mod. Date: 10/18/2022
TID #: N/A	Project Title: TMS320F28388D controlCARD	
Number: MCU063	Rev: B	Sheet Title:
SVN Rev: Version control disabled	Assembly Variant: 003	Sheet: 4 of 11
Drawn By: Cody Watkins	File: MCU063B_ADC.SchDoc	Size: B
Engineer: Cody Watkins	Contact: http://www.ti.com/support	



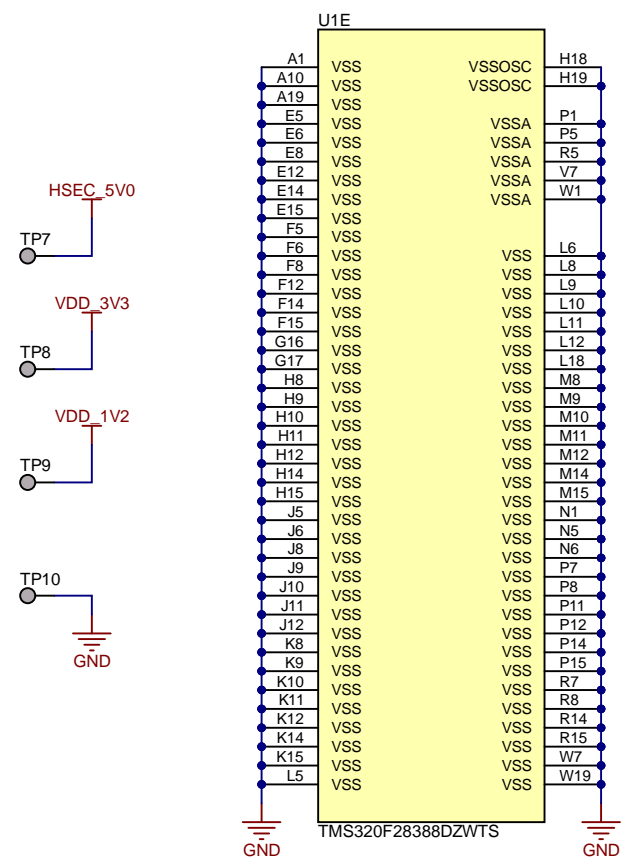

1.2V and 3.3V Supplies

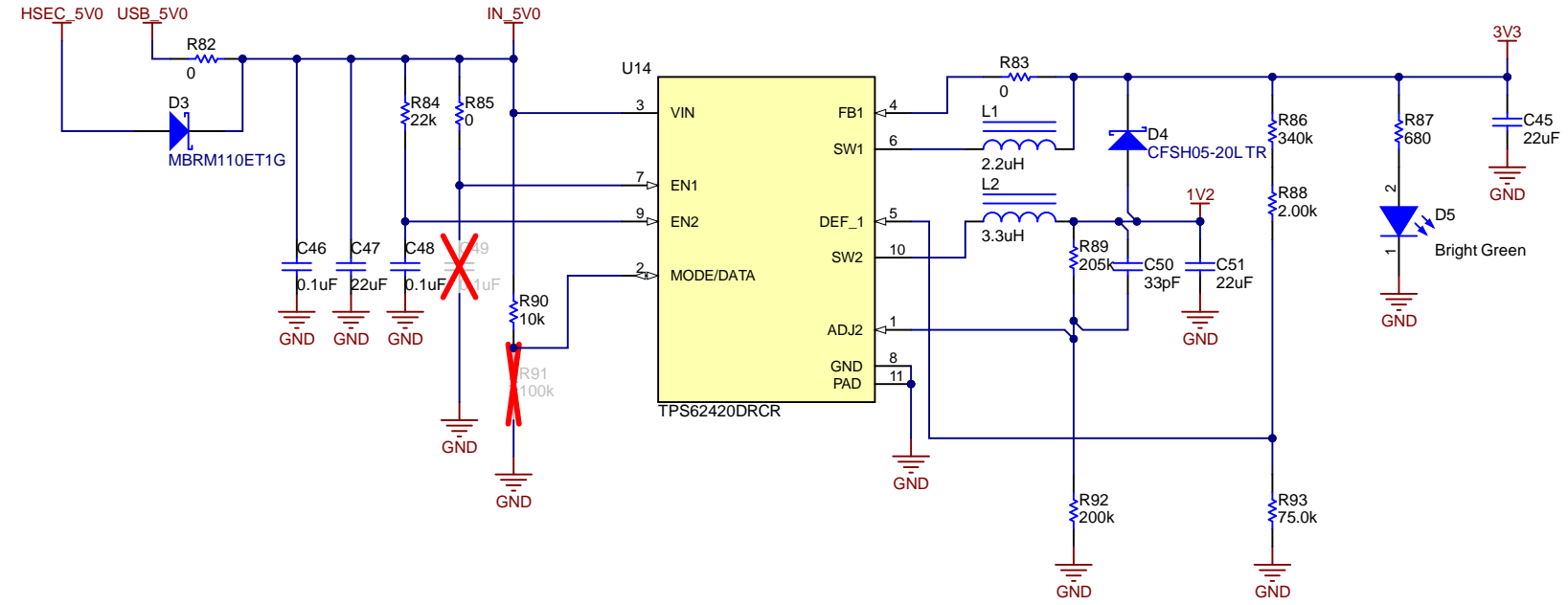

Decoupling Capacitors

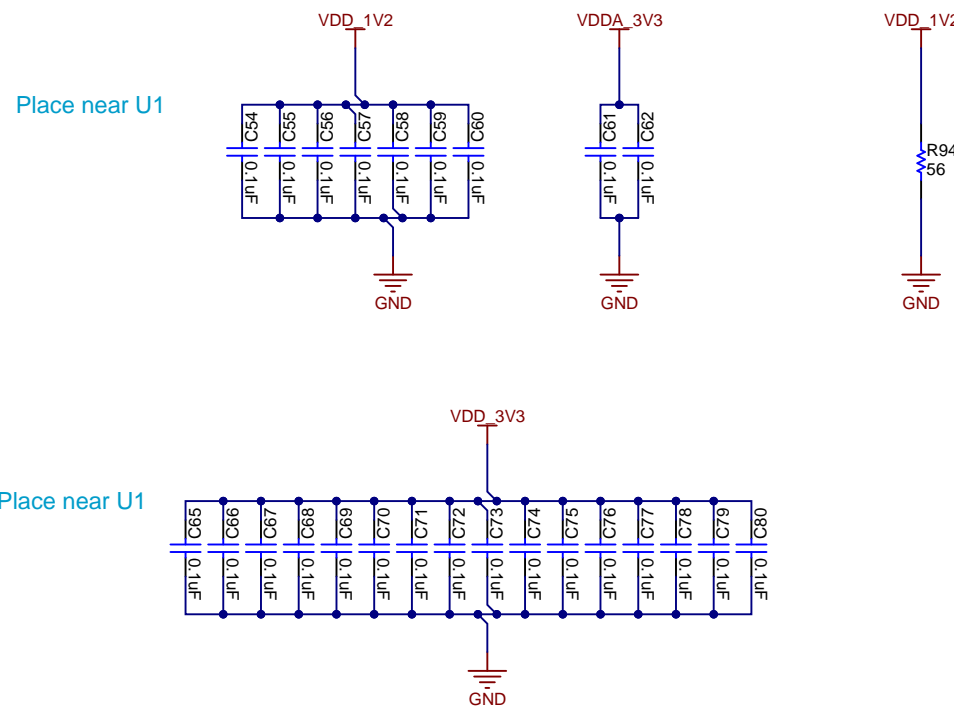
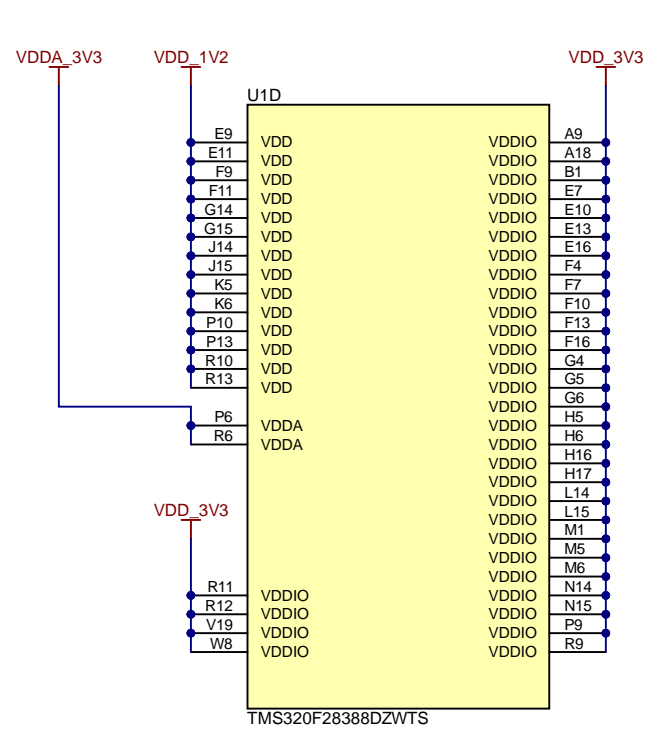

Ferrite Beads

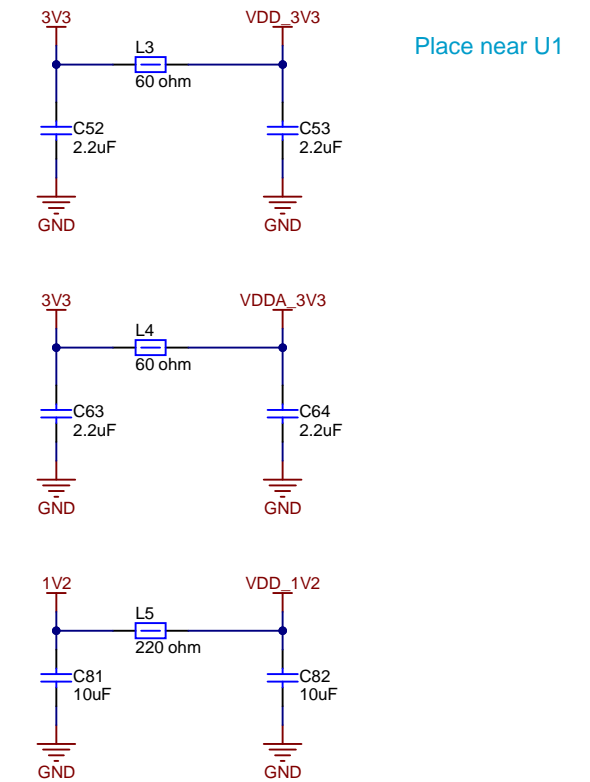

Texas Instruments and/or its licensors do not warrant the accuracy or completeness of this specification or any information contained therein. Texas Instruments and/or its licensors do not warrant that this design will meet the specifications, will be suitable for your application or fit for any particular purpose, or will operate in an implementation. Texas Instruments and/or its licensors do not warrant that the design is production worthy. You should completely validate and test your design implementation to confirm the system functionality for your application.

Orderable: TMS320F28388D	Designed for: Public Release	Mod. Date: 10/18/2022
TID #: N/A	Project Title: TMS320F28388D controlCARD	
Number: MCU063	Rev: B	Sheet Title:
SVN Rev: Version control disabled	Assembly Variant: 003	Sheet: 5 of 11
Drawn By: Cody Watkins	File: MCU063B_Power.SchDoc	Size: B
Engineer: Cody Watkins	Contact: http://www.ti.com/support	



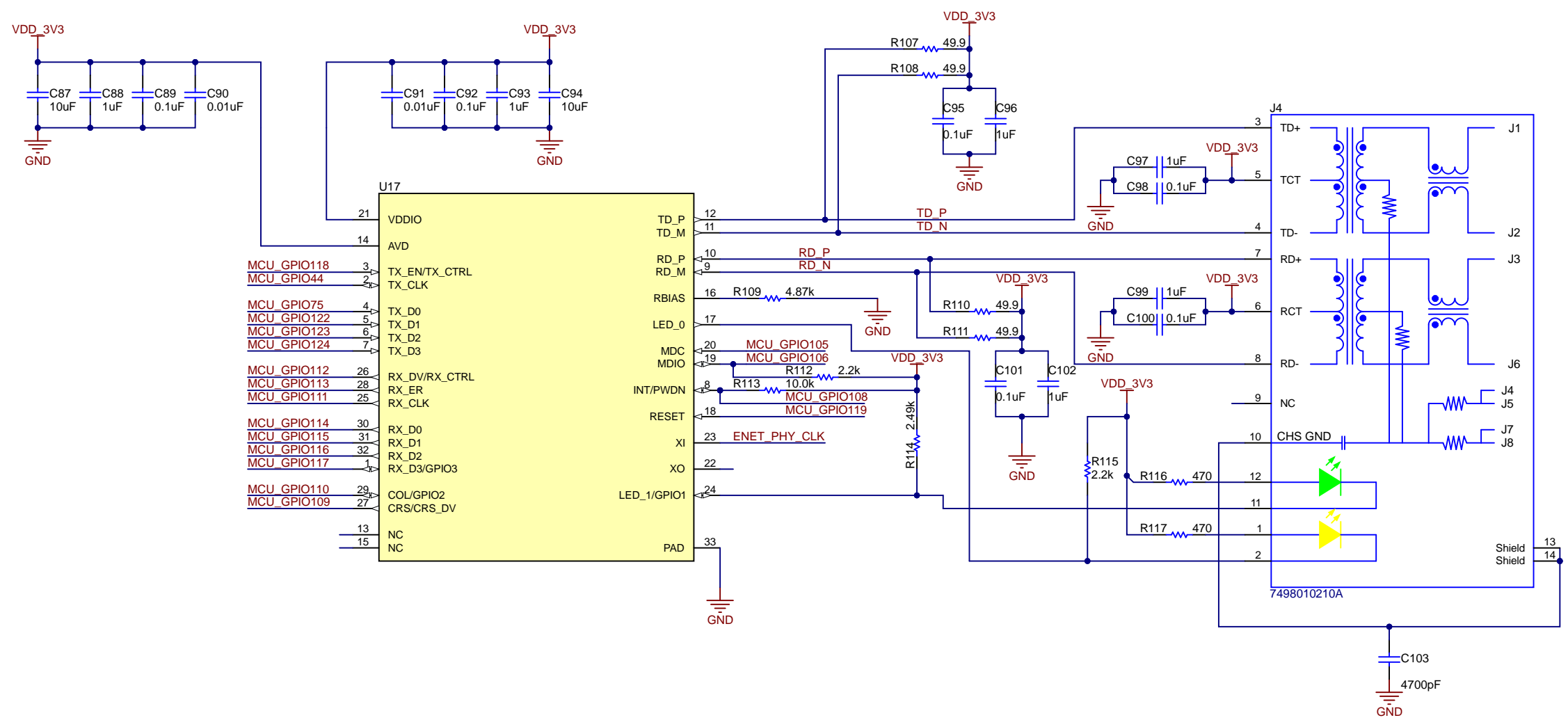

Texas Instruments and/or its licensors do not warrant the accuracy or completeness of this specification or any information contained therein. Texas Instruments and/or its licensors do not warrant that this design will meet the specifications, will be suitable for your application or fit for any particular purpose, or will operate in an implementation. Texas Instruments and/or its licensors do not warrant that the design is production worthy. You should completely validate and test your design implementation to confirm the system functionality for your application.

Orderable: TMDSCNCD28388D	Designed for: Public Release	Mod. Date: 10/18/2022
TID #: N/A	Project Title: TMS320F28388D controlCARD	
Number: MCU063	Rev: B	Sheet Title:
SVN Rev: Version control disabled	Assembly Variant: 003	Sheet: 7 of 11
Drawn By:	File: MCU063B_EtherNET.SchDoc	Size: B
Engineer: Cody Watkins	Contact: http://www.ti.com/support	



EtherCAT EEPROM

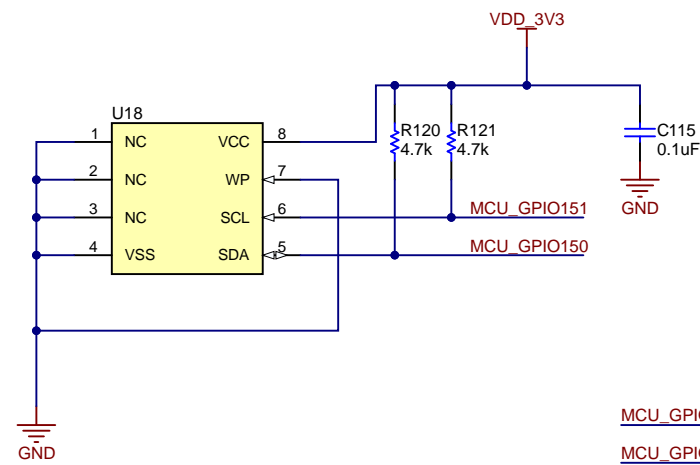

EtherCAT P0

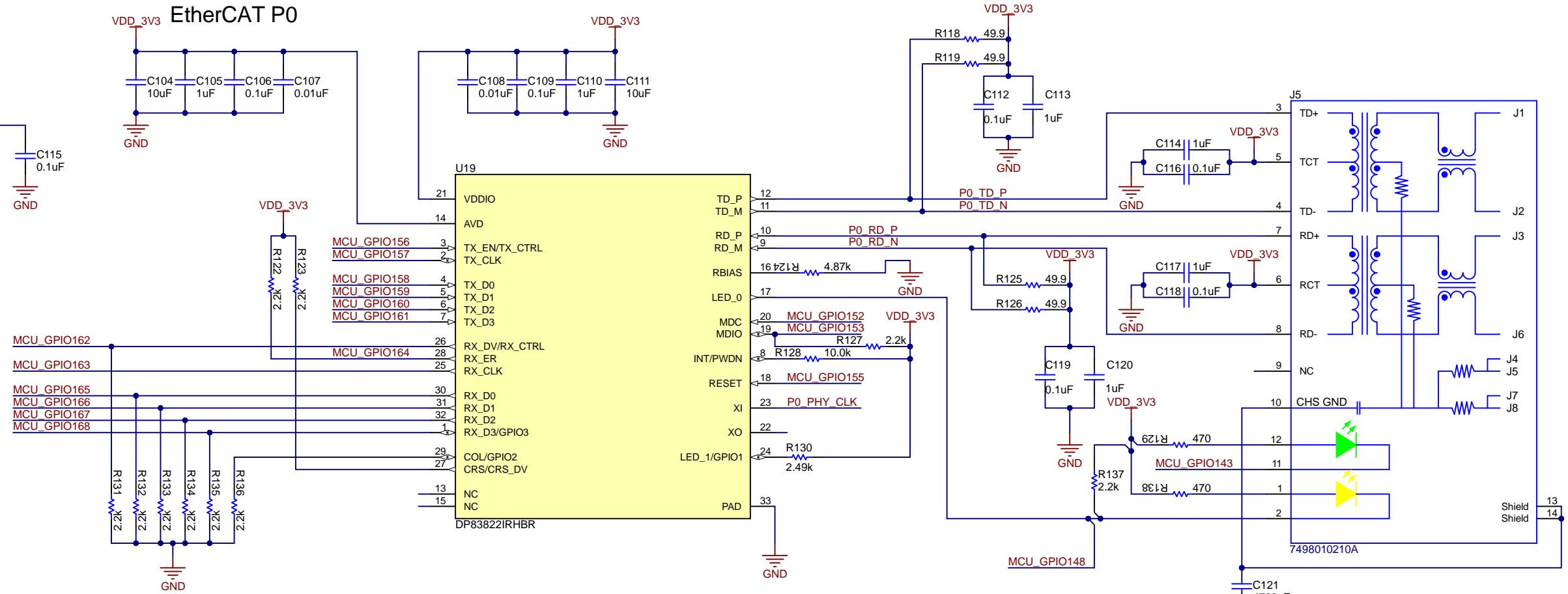

Run and Error LEDs

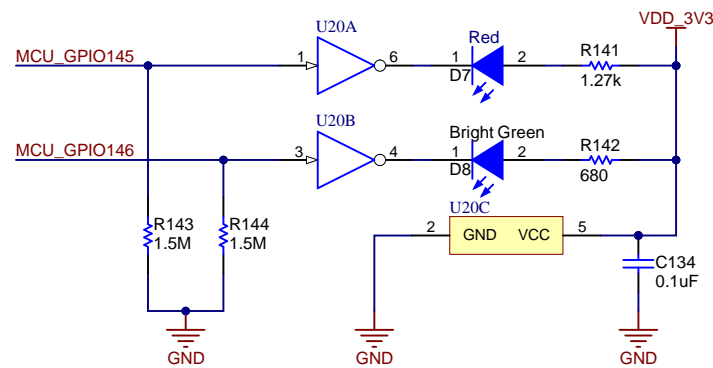

EtherCAT P1

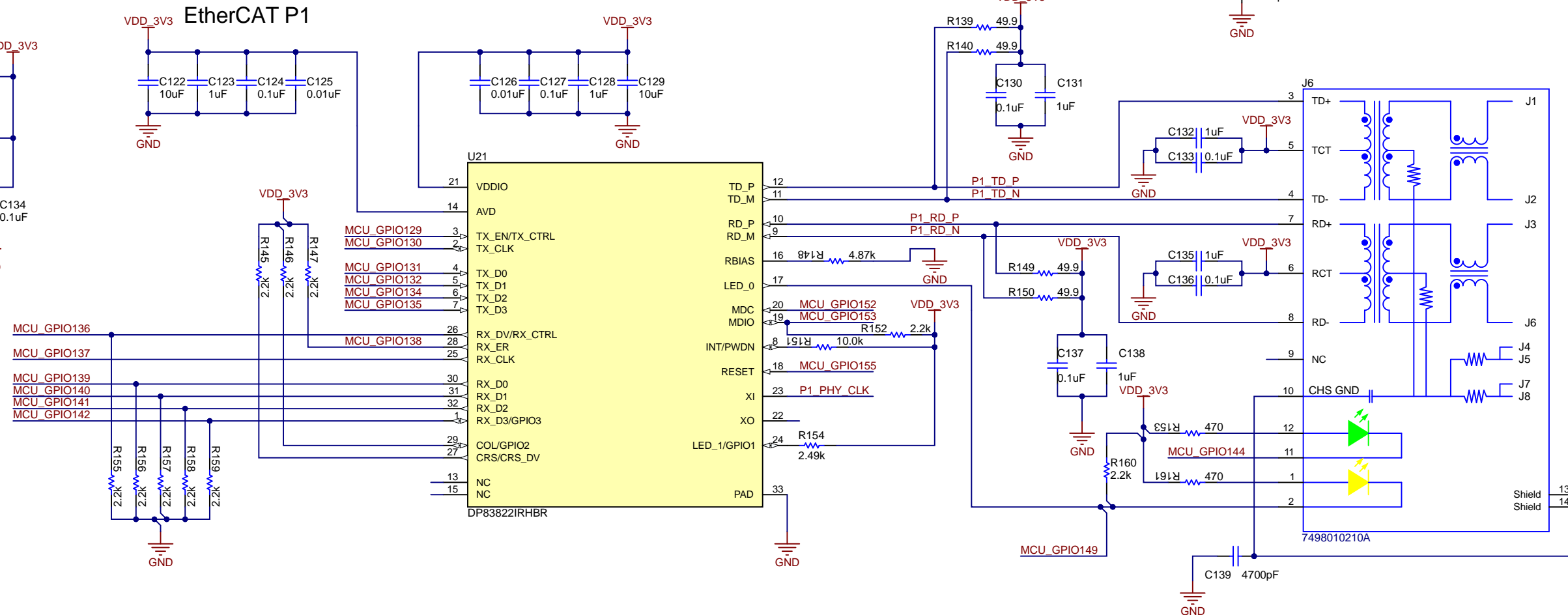

Texas Instruments and/or its licensors do not warrant the accuracy or completeness of this specification or any information contained therein. Texas Instruments and/or its licensors do not warrant that this design will meet the specifications, will be suitable for your application or fit for any particular purpose, or will operate in an implementation. Texas Instruments and/or its licensors do not warrant that the design is production worthy. You should completely validate and test your design implementation to confirm the system functionality for your application.

Orderable: TMS320F28388D	Designed for: Public Release	Mod. Date: 10/18/2022
TID #: N/A	Project Title: TMS320F28388D controlCARD	
Number: MCU063	Rev: B	Sheet Title:
SVN Rev: Version control disabled	Assembly Variant: 003	Sheet: 8 of 11
Drawn By:	File: MCU063B_EtherCAT.SchDoc	Size: B
Engineer: Cody Watkins	Contact: http://www.ti.com/support	

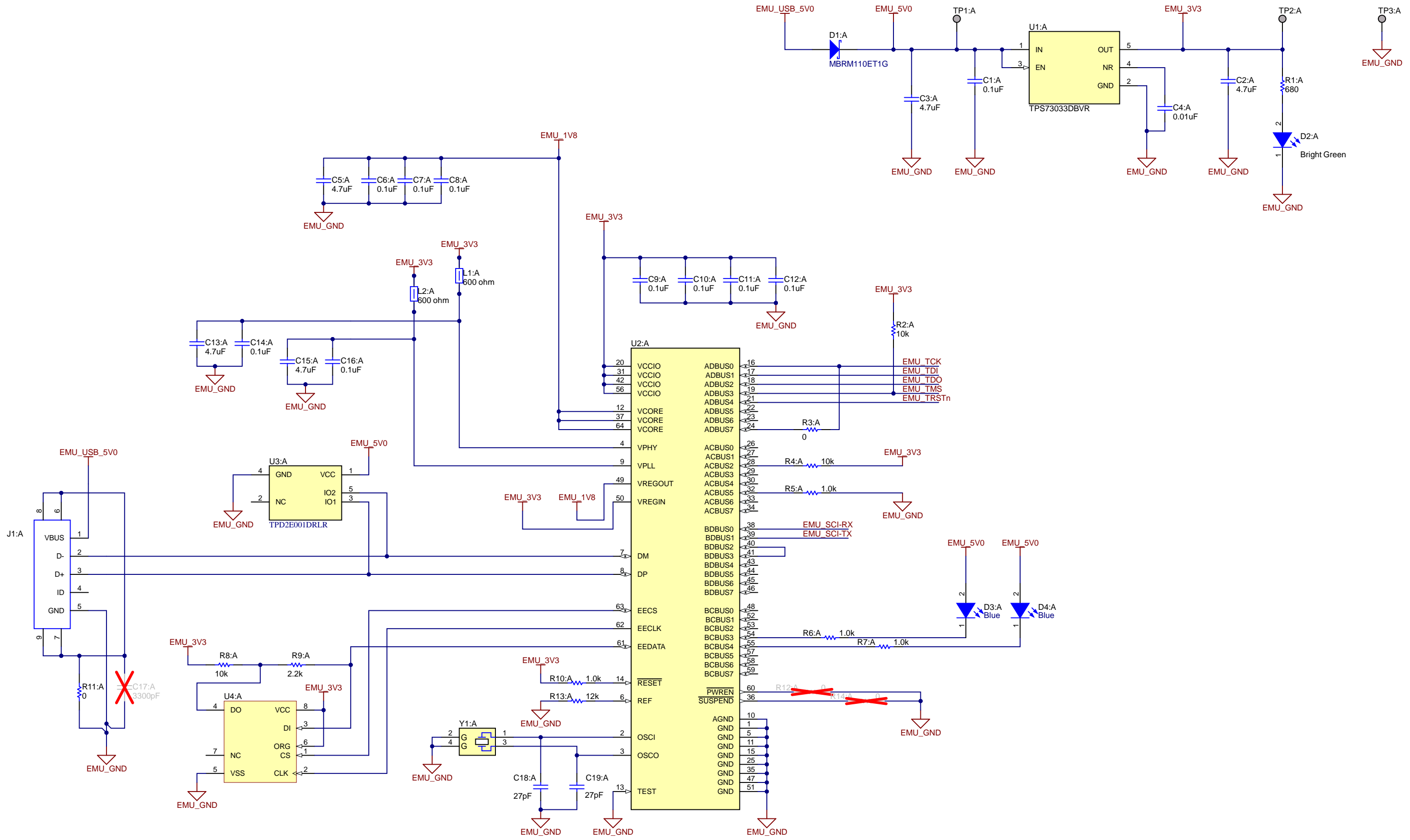

Texas Instruments and/or its licensors do not warrant the accuracy or completeness of this specification or any information contained therein. Texas Instruments and/or its licensors do not warrant that this design will meet the specifications, will be suitable for your application or fit for any particular purpose, or will operate in an implementation. Texas Instruments and/or its licensors do not warrant that the design is production worthy. You should completely validate and test your design implementation to confirm the system functionality for your application.

Orderable: TMDSCNCD28388D	Designed for: Public Release	Mod. Date: 10/18/2022
TID #: N/A	Project Title: TMS320F28388D controlCARD	
Number: MCU063	Rev: B	Sheet Title:
SVN Rev: Version control disabled	Assembly Variant: 003	Sheet: 9 of 11
Drawn By: Cody Watkins	File: MCU063B_Emulator.SchDoc	Size: B
Engineer: Cody Watkins	Contact: http://www.ti.com/support	



 http://www.ti.com

 © Texas Instruments 2018

S1:A - Emulation & GPIO28 Switch

- POS 1 ON: Use xds100v2 emulator that is on the cCARD
- POS 1 OFF: Boot from FLASH/peripheral (see boot mode switch) OR use emulator on baseboard
- POS 2 ON: GPIO28 will be controlled by the USB-to-UART adapter on the FTDI chip
- POS 2 OFF: GPIO28 can be controlled by a pin in HSEC connector

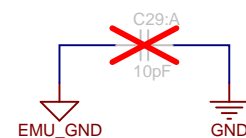
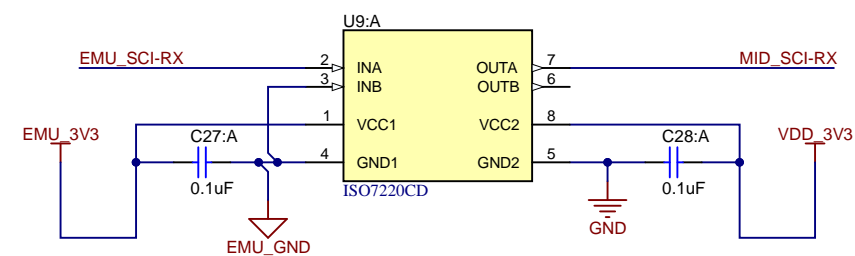
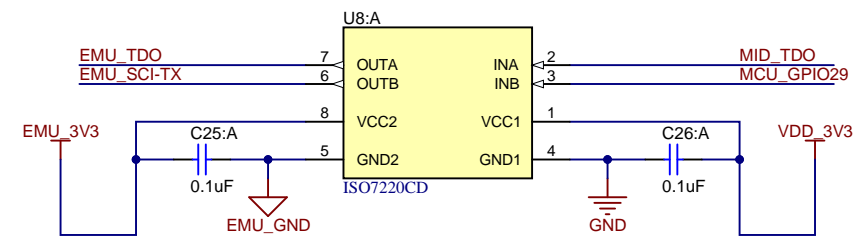
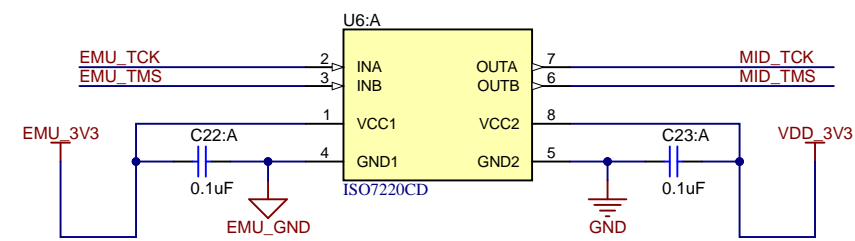
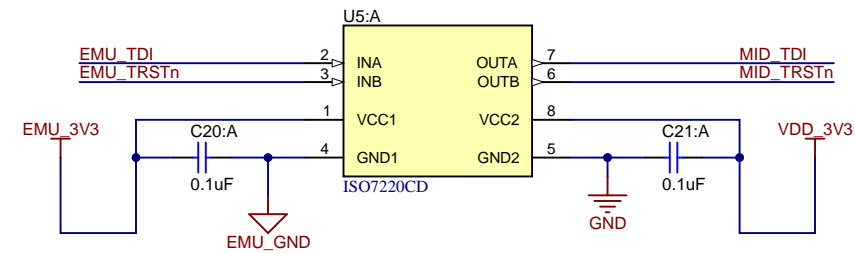

WARNING: To avoid potential shock hazard in a high-voltage setting, it is strongly recommended to remove the Y cap (C29:A) from the EVM.

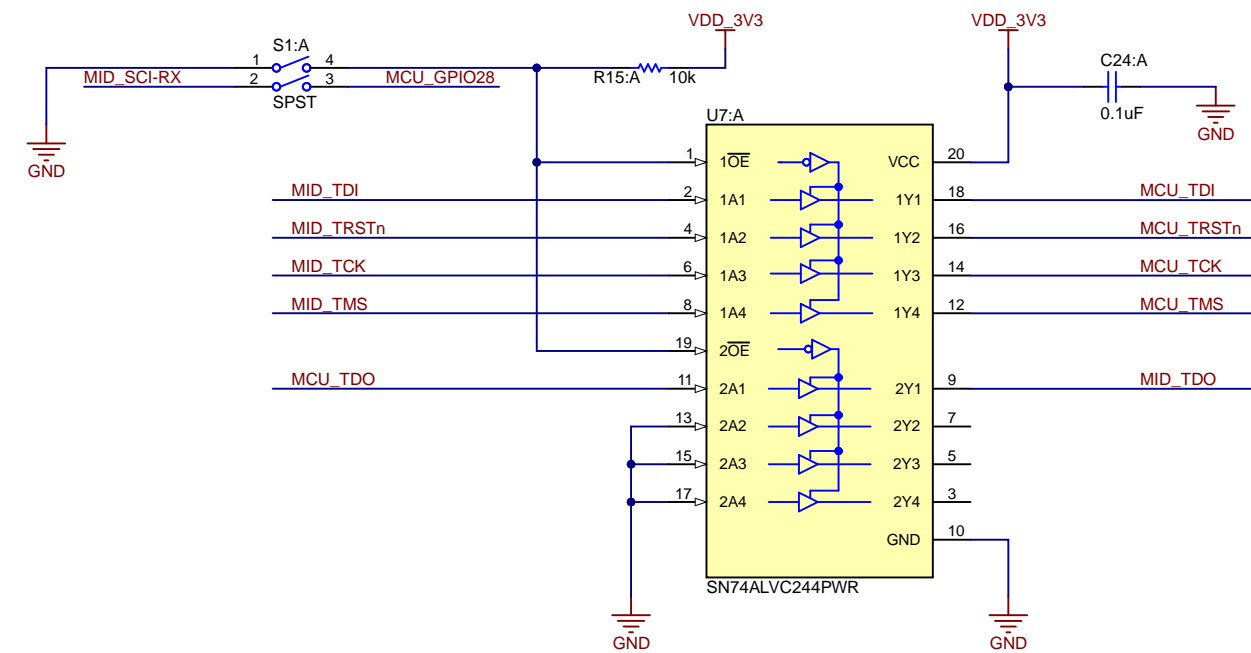



PCB Number: MCU063
PCB Rev: B

PCB LOGO
Texas Instruments



PCB LOGO
FCC disclaimer

PCB LOGO
WEEE logo

PCB LOGO
ETHERCAT LABEL

Variant/Label Table	
Variant	Label Text
001	TMDXCNC28388D
002	TMDSCNCD28388D
003	TMDSCNCD28388D - w/ C29:A DNP

LBL1
PCB Label

THT-14-423-10
Size: 0.65" x 0.20 "

ZZ1
Label Assembly Note
This Assembly Note is for PCB labels only

ZZ2
Assembly Note
These assemblies are ESD sensitive, ESD precautions shall be observed.

ZZ3
Assembly Note
These assemblies must be clean and free from flux and all contaminants. Use of no clean flux is not acceptable.

ZZ4
Assembly Note
These assemblies must comply with workmanship standards IPC-A-610 Class 2, unless otherwise specified.

Orderable: TMDSCNCD28388D	Designed for: Public Release	Mod. Date: 10/17/2022
TID #: N/A	Project Title: TMS320F28388D controlCARD	
Number: MCU063	Rev: B	Sheet Title:
SVN Rev: Version control disabled	Assembly Variant: 003	Sheet: 11 of 11
Drawn By:	File: MCU063B_EVM_Hardware.SchDoc	Size: B
Engineer: Cody Watkins	Contact: http://www.ti.com/support	

Texas Instruments and/or its licensors do not warrant the accuracy or completeness of this specification or any information contained therein. Texas Instruments and/or its licensors do not warrant that this design will meet the specifications, will be suitable for your application or fit for any particular purpose, or will operate in an implementation. Texas Instruments and/or its licensors do not warrant that the design is production worthy. You should completely validate and test your design implementation to confirm the system functionality for your application.