

Legal owner Diakont	Created by	Title/supplementary title Power module 8 kW			
	Checked by	Document status			
Document type Electrical schematic diagram	Approved by	Designation 3DDIA.426411.004&EFS	Rev. A	Date of approved	Lang. En.
					Sheet 1 / 12

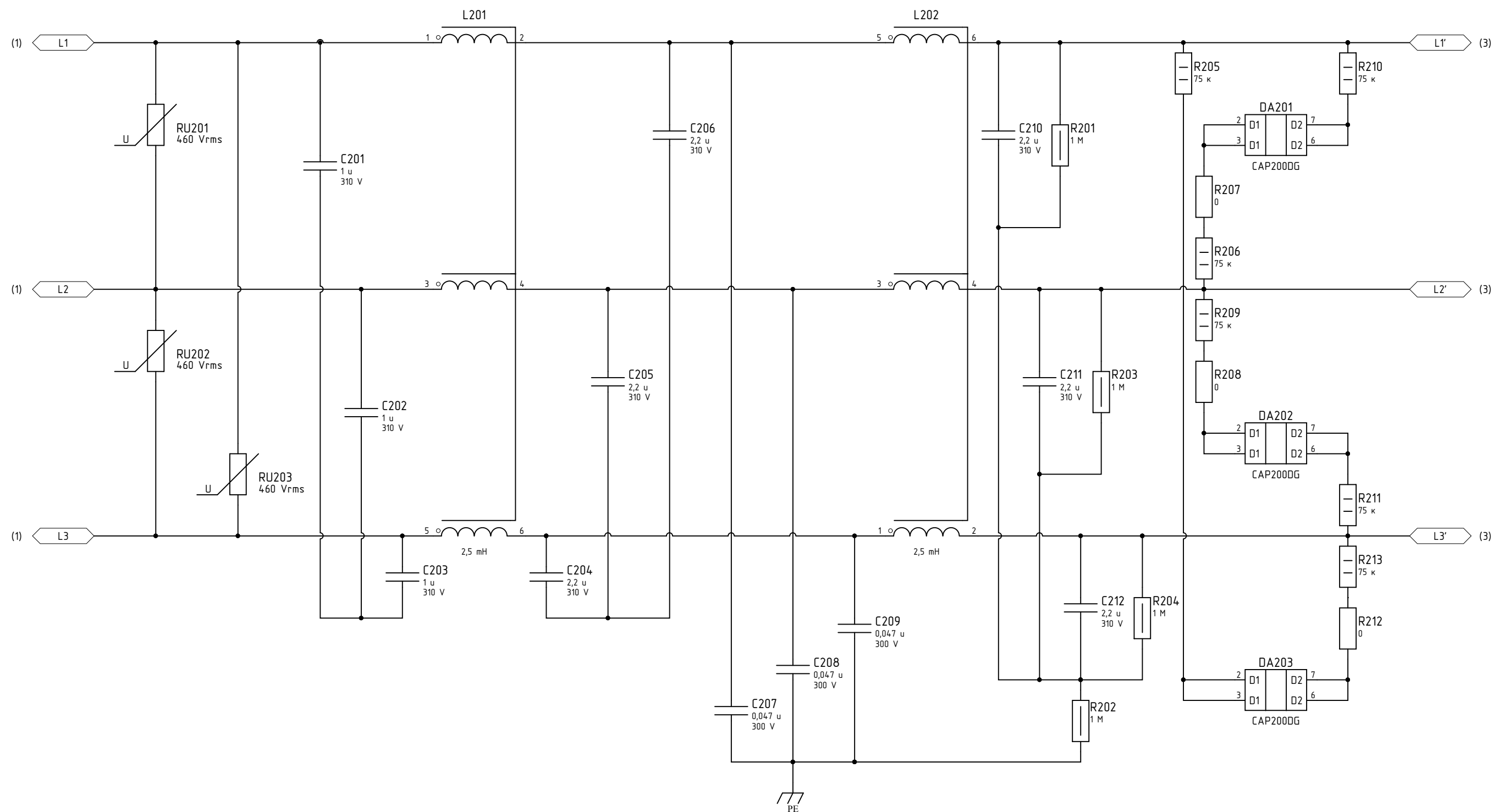

Legal owner Diakont	Title/supplementary title Power module 8 kW	Designation 3DDIA.426411.004&EFS		
		Rev. A	Date of approved	Lang. En.
				Sheet 2/12

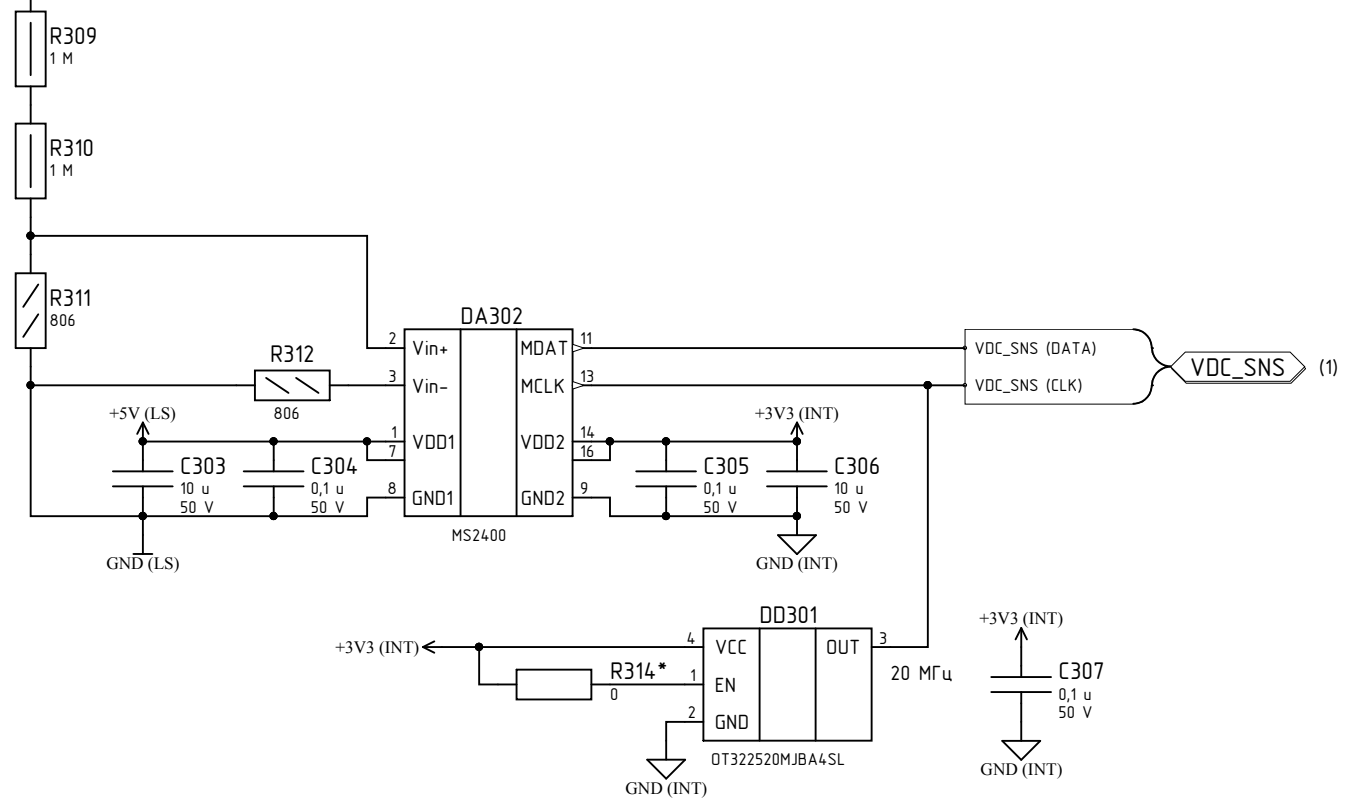
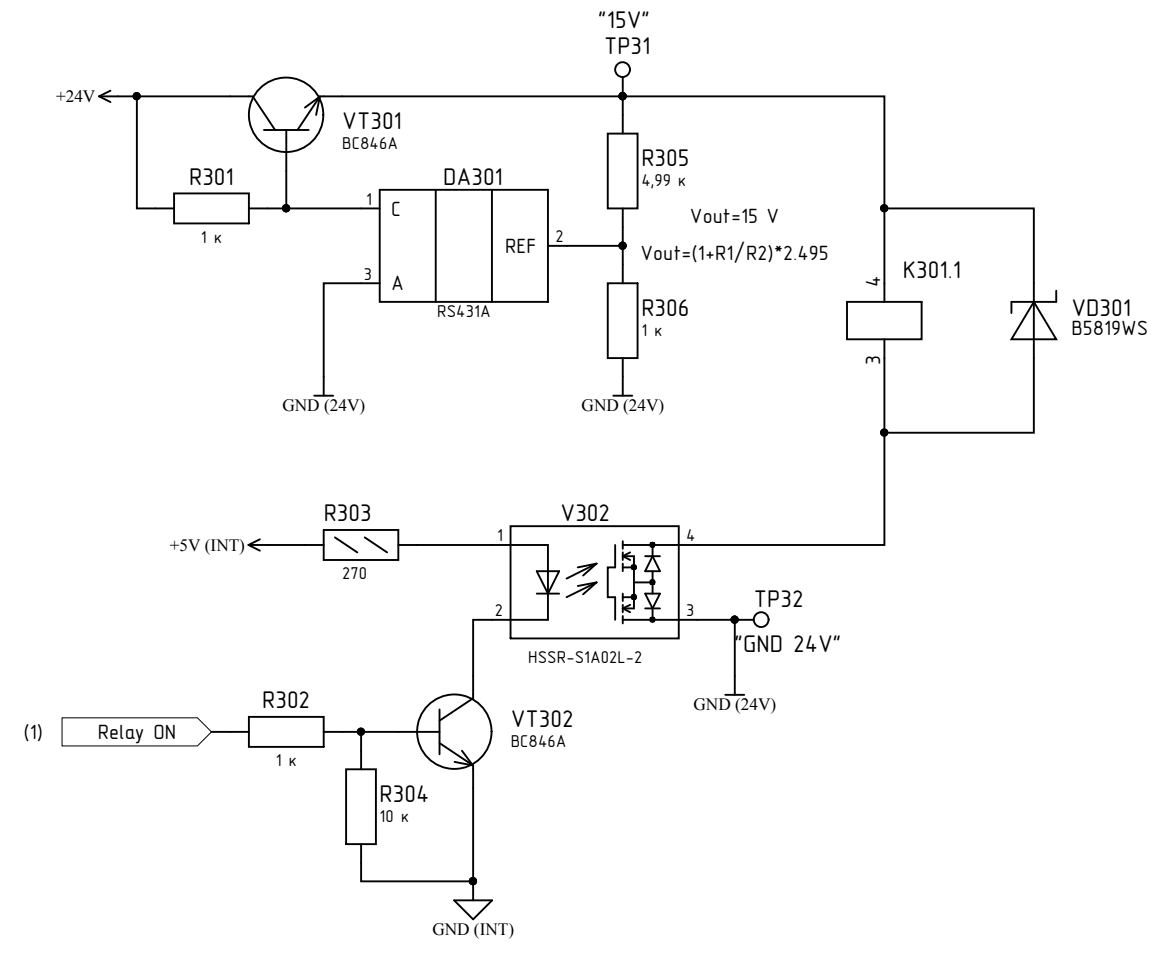
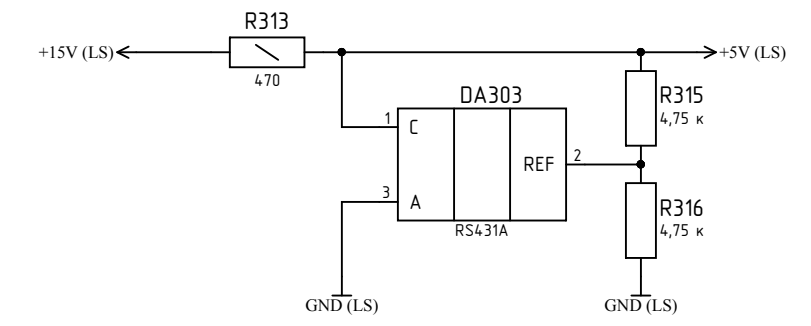
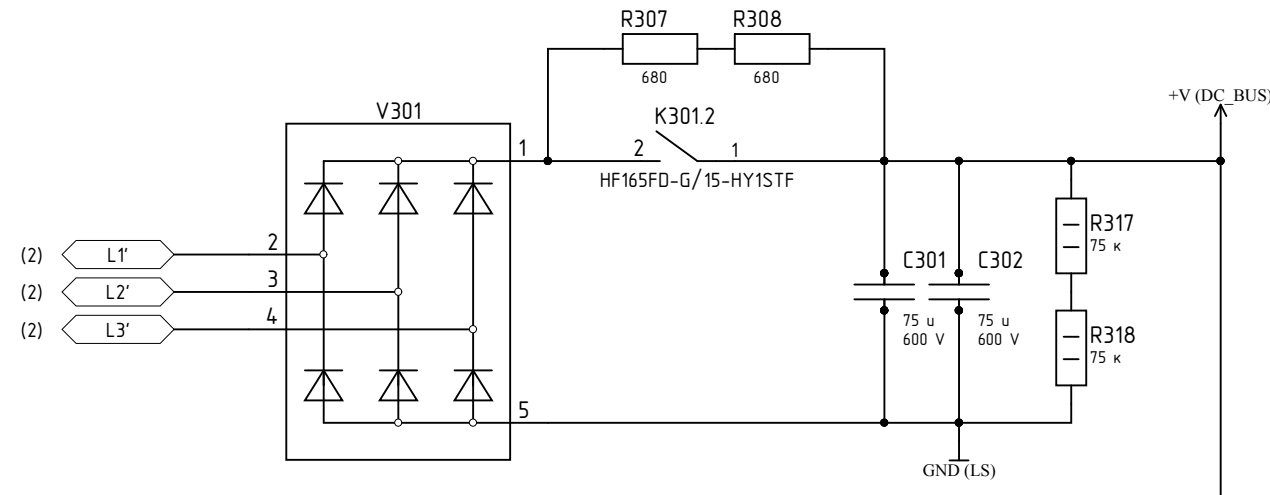

Legal owner Diakont	Title/supplementary title Power module 8 kW	Designation 3DDIA.426411.004&EFS			
		Rev. A	Date of approved	Lang. En.	Sheet 3/12

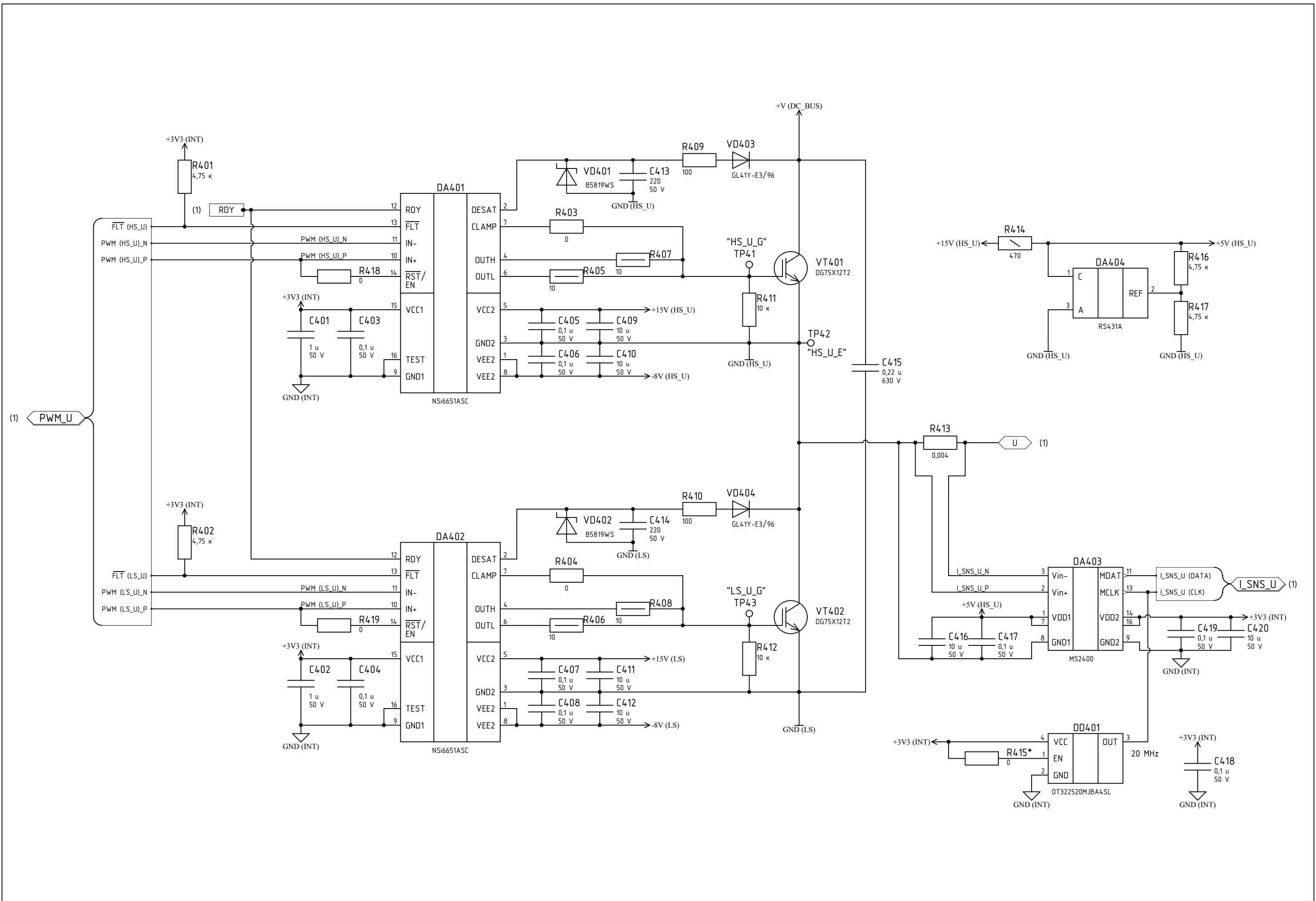

Legal owner Diakont		Title/supplementary title Power module 8 kW		Designation 3DDIA.426411.004&EFS	
Rev. A	Date of approved	Lang. En.	Sheet 4/12		

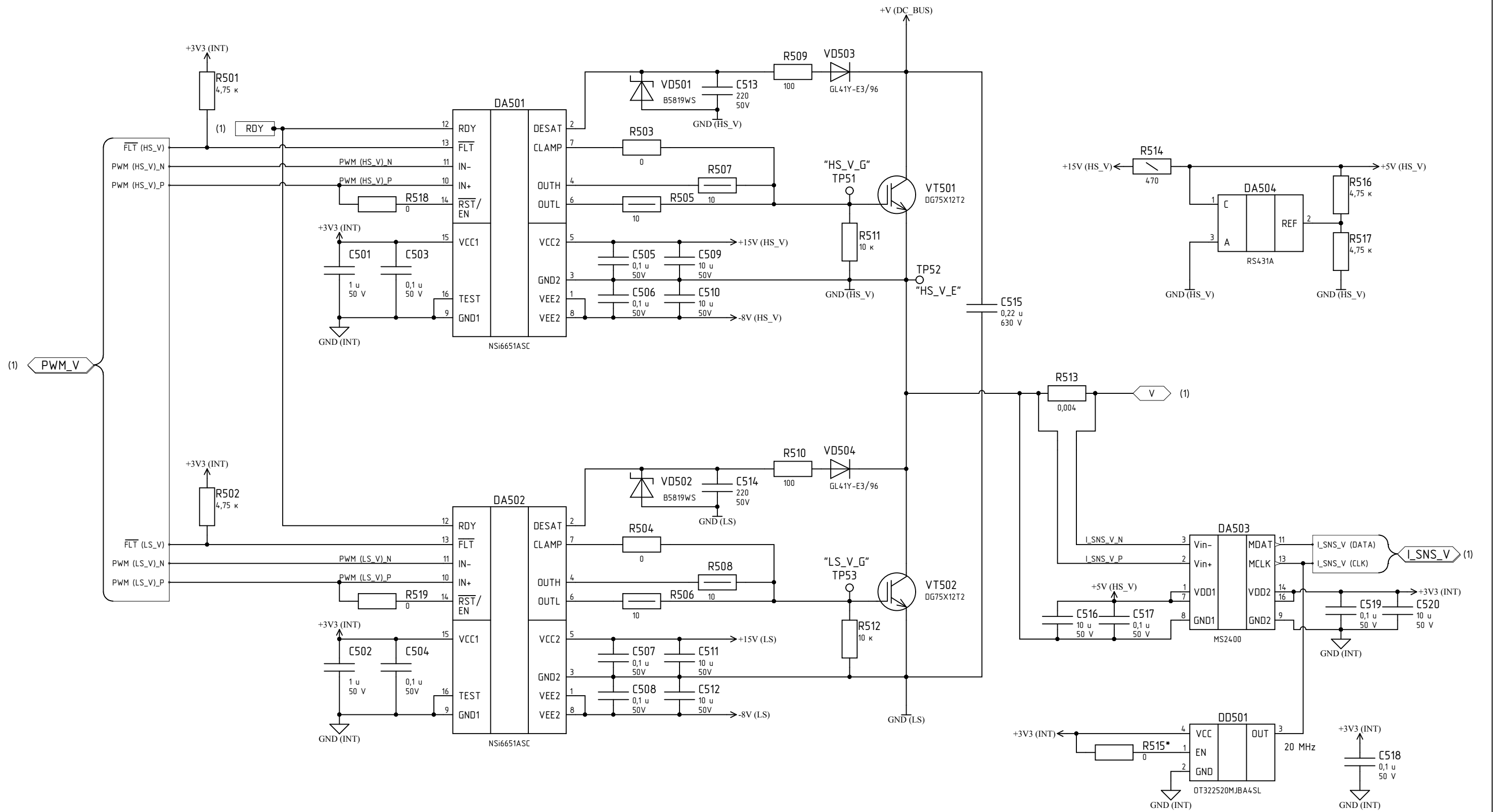

Legal owner Diakont	Title/supplementary title Power module 8 kW	Designation 3DDIA.426411.004&EFS	Rev. A	Date of approved	Lang. En.	Sheet 5/12
------------------------	--	--	-----------	------------------	--------------	---------------

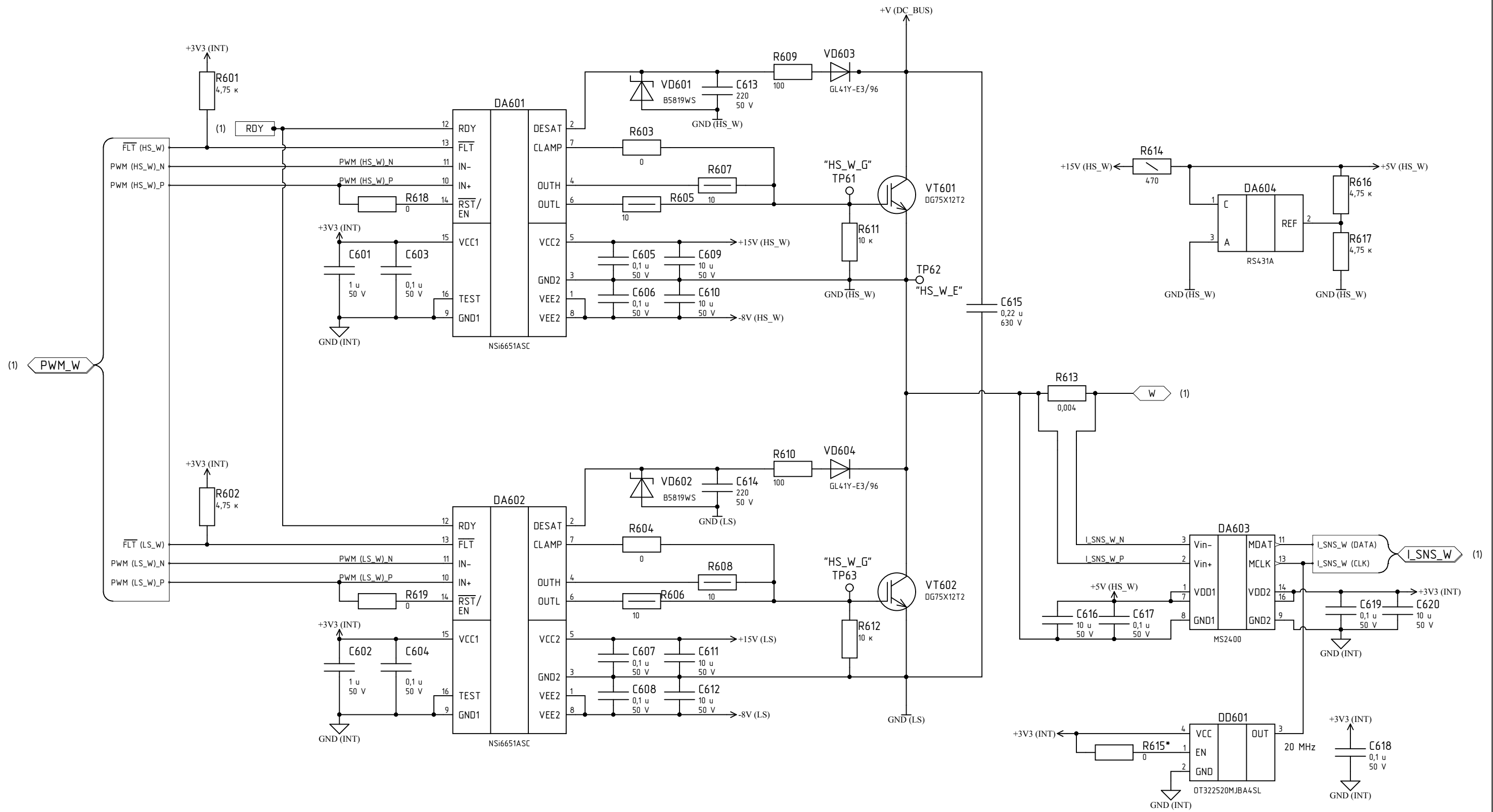

Legal owner Diakont		Title/supplementary title Power module 8 kW		Designation 3DDIA.426411.004&EFS		
Rev. A	Date of approved	Lang. En.	Sheet 6/12			

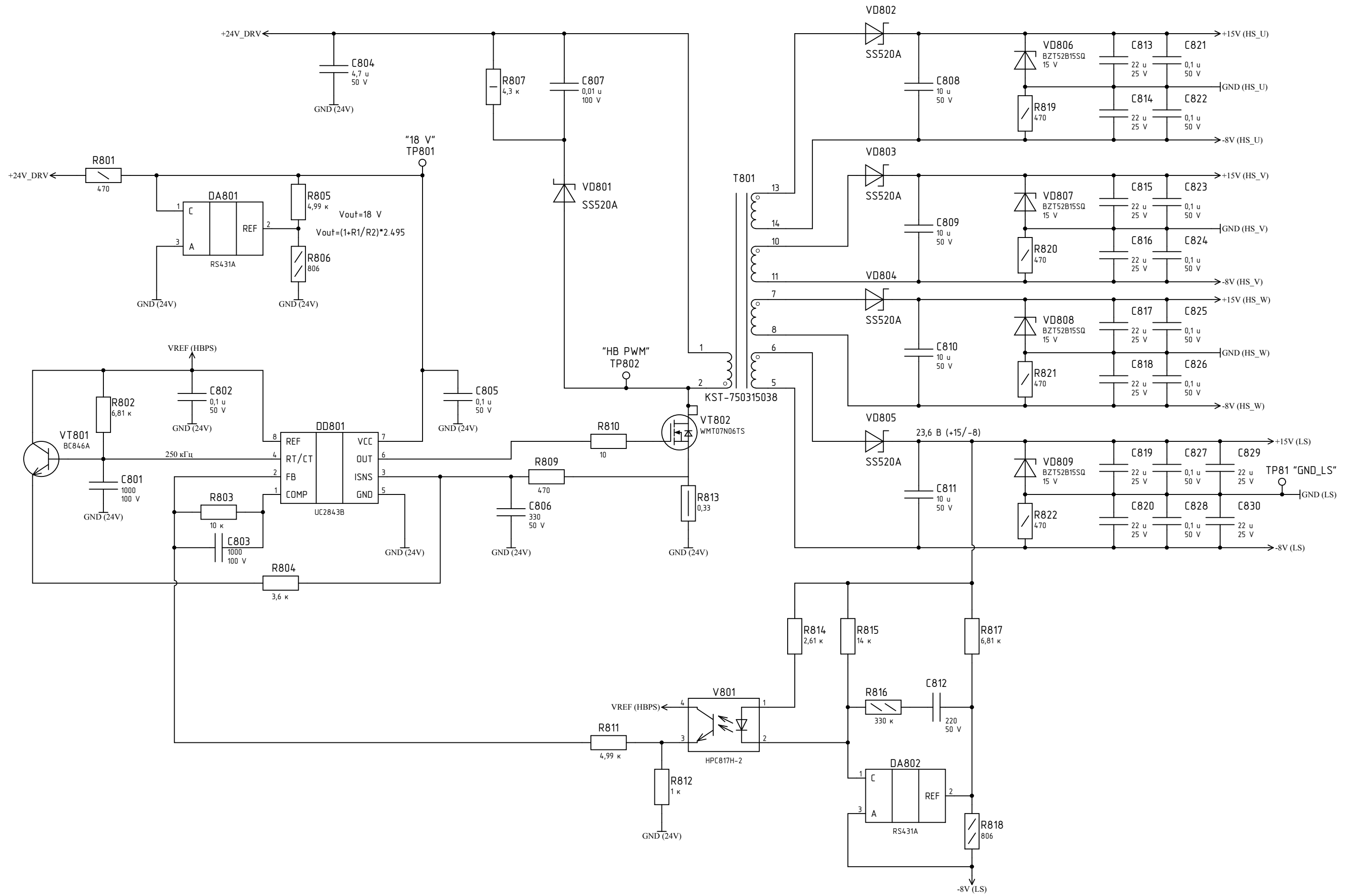

Legal owner Diakont	Title/supplementary title Power module 8 kW	Designation 3DDIA.426411.004&EFS	Rev. A	Date of approved	Lang. En.	Sheet 8/12
------------------------	--	--	-----------	------------------	--------------	---------------

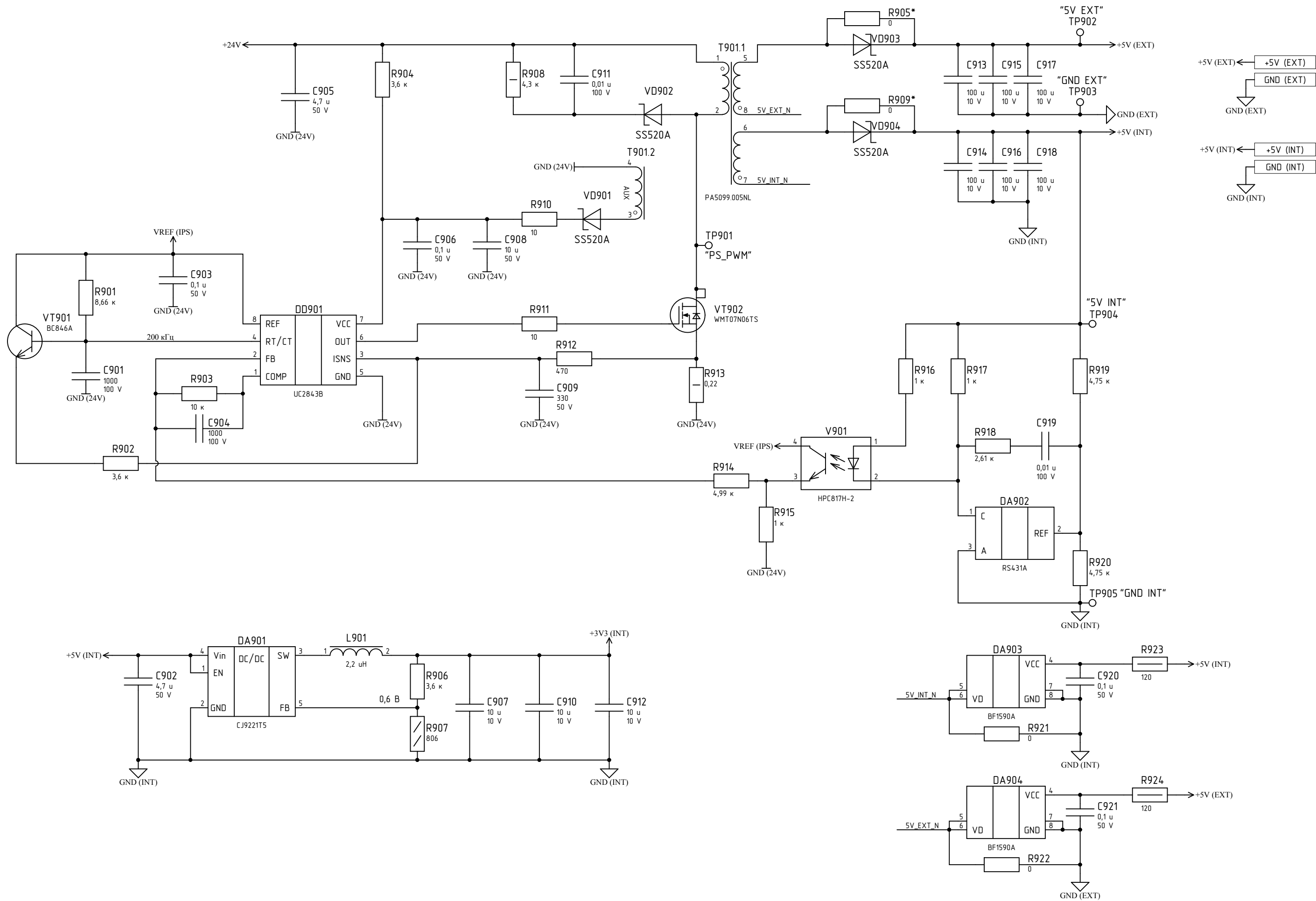

Legal owner Diakont	Title/supplementary title Power module 8 kW	Designation 3DDIA.426411.004&EFS	Rev. A	Date of approved	Lang. En.	Sheet 9/12
------------------------	--	--	-----------	------------------	--------------	---------------

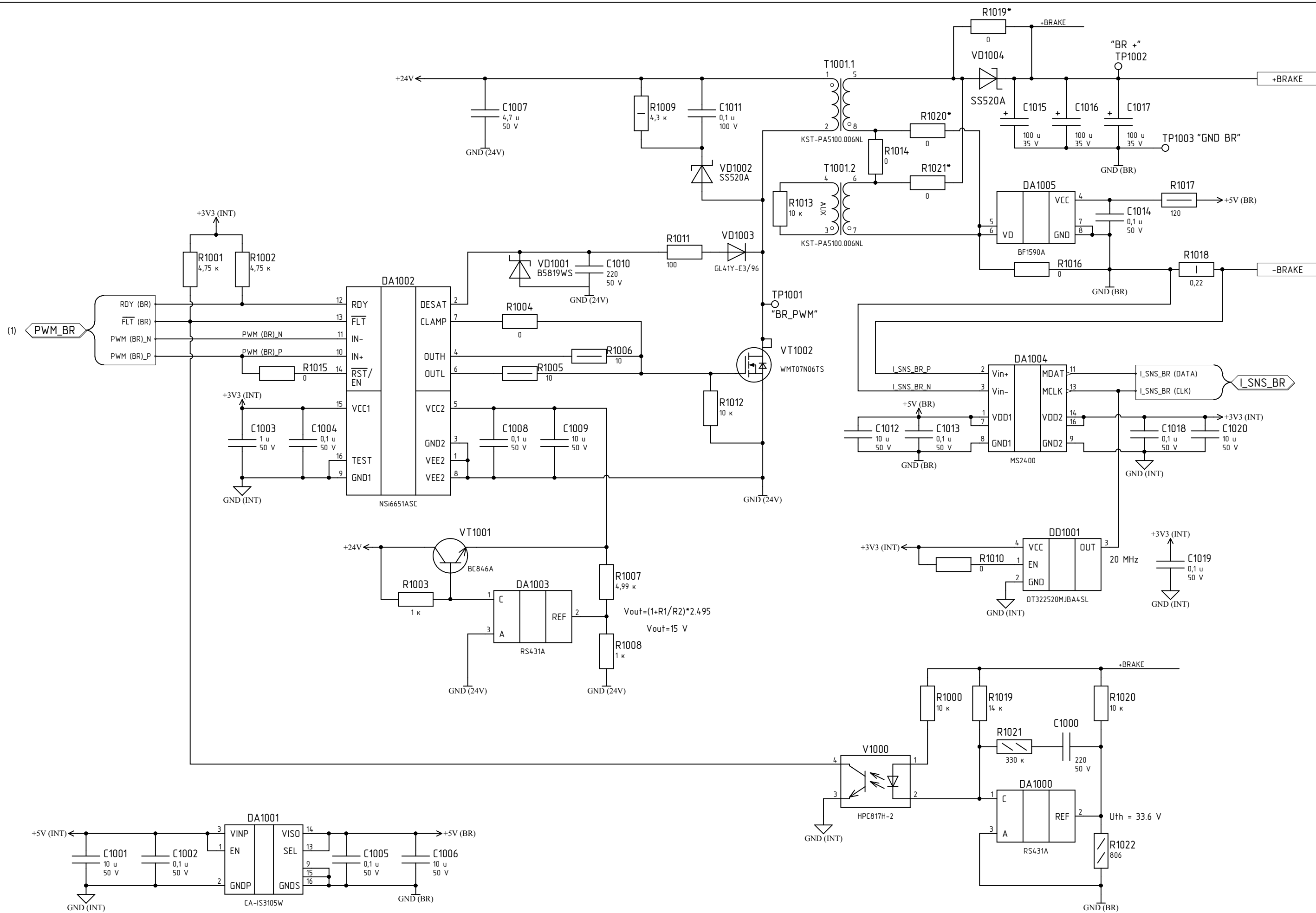

Legal owner Diakont	Title/supplementary title Power module 8 kW	Designation 3DDIA.426411.004&EFS	Rev. A	Date of approved	Lang. En.	Sheet 10/12
------------------------	--	--	-----------	------------------	--------------	----------------

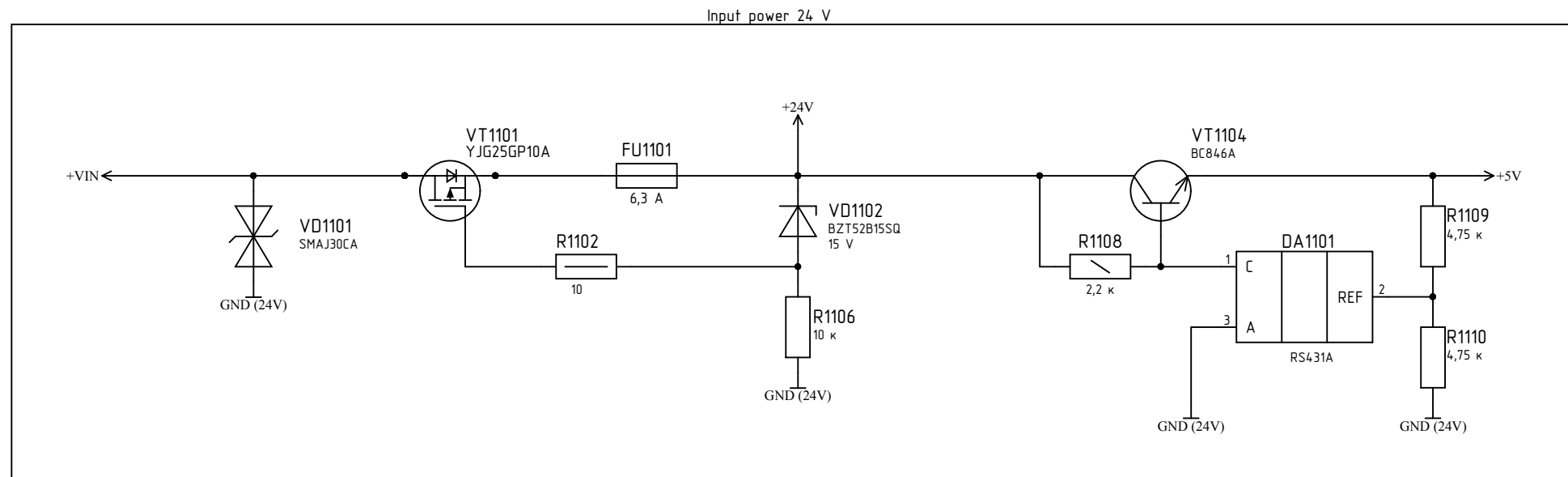

EEPROM

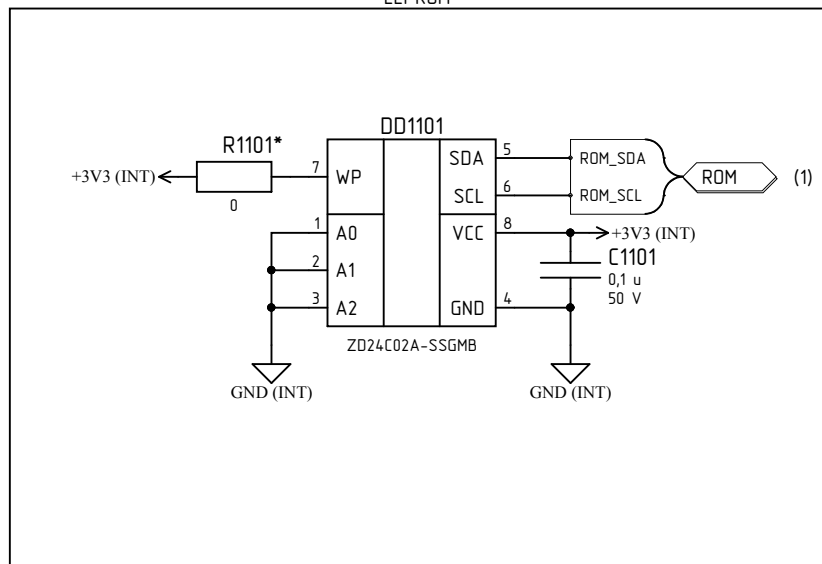

FAN Control

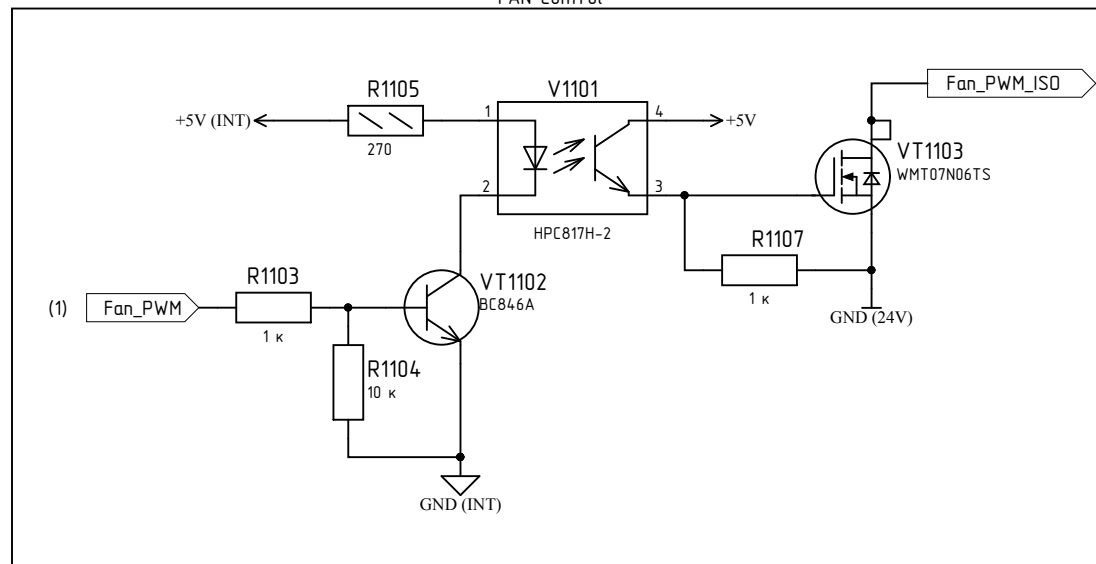

Temperature sensor

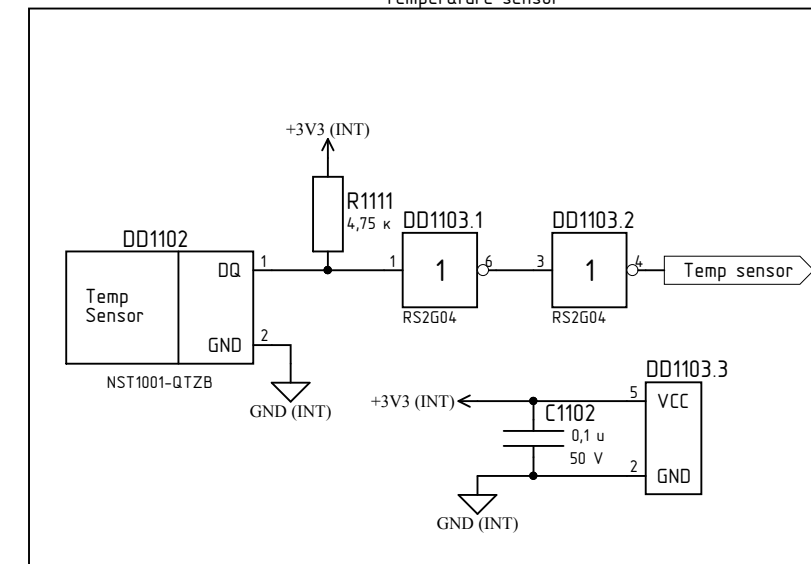

Legal owner Diakont	Title/supplementary title Power module 8 kW	Designation 3DDIA.426411.004&EFS			
		Rev. A	Date of approved	Lang. En.	Sheet 11/12

STO discrete signals processing
Discrete inputs in accordance with IEC 61131-2 (for inputs type 1)

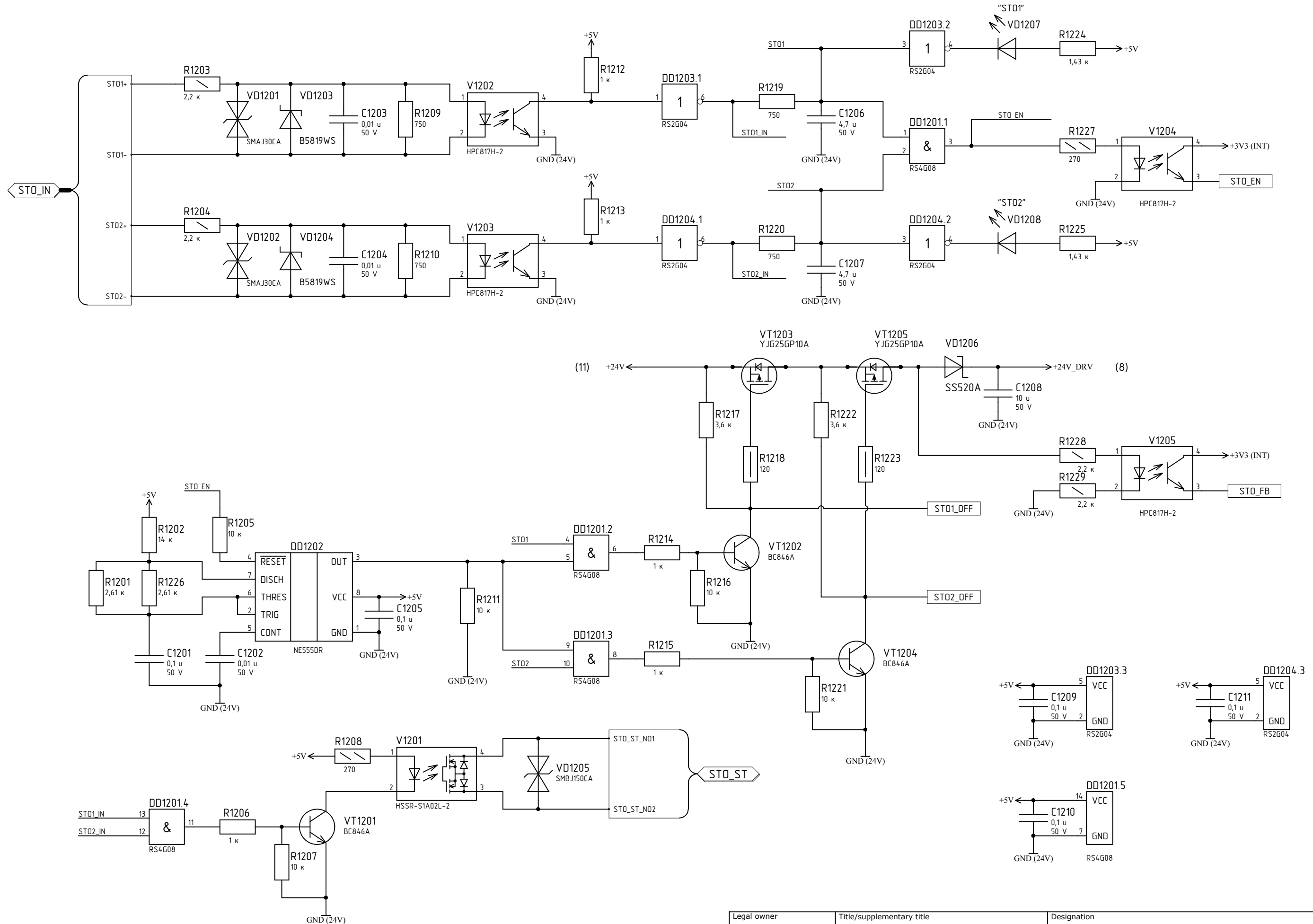

Legal owner Diakont	Title/supplementary title Power module 8 kW	Designation 3DDIA.426411.004&EFS	Rev. A	Date of approved	Lang. En.	Sheet 12/12
------------------------	--	--	-----------	------------------	--------------	----------------